

ABERDEEN

Community Development District

MAY 30, 2023

AGENDA

Aberdeen
Community Development District

475 West Town Place

Suite 114

St. Augustine, Florida 32092

District Website: www.AberdeenCDD.com

May 23, 2023

Board of Supervisors
Aberdeen Community Development District

Dear Board Members:

The Aberdeen Community Development District Meeting is scheduled for **Tuesday, May 30, 2023 at 6:00 p.m.** at the Aberdeen Amenity Center, 110 Flower of Scotland Avenue, St. Johns, Florida 32259.

Following is the advance agenda for the meeting:

- I. Roll Call
- II. Public Comments (*regarding agenda items below*)
- III. Review and Discussion of Quality Assurance Inspection Report and Action Items
- IV. Consideration of Proposals (*as provided by staff*)
 - A. Furniture Proposals for Fitness Center Area
- V. Update Regarding Removal or Trimming of Trees and Brush in Preserve Areas
- VI. Fiscal Year 2024 Budget Process
 - A. Review of Proposed Budget (*will be sent under separate cover*)
 - B. Consideration of Resolution 2023-04, Adopting Fiscal Year 2024 Budget and Setting Budget Hearing for Adoption (August 22nd @ 6:00 p.m.)
- VII. Staff Reports
 - A. Attorney

- B. Engineer
- C. Manager – Report on the Number of Registered Voters (3,656)
- D. Operation Manager
- E. Amenity Center Manager - Report

VIII. Supervisor’s Request and Public Comments

IX. Approval of Consent Agenda

- A. Approval of the Minutes of the April 25, 2023 Meeting
- B. Balance Sheet as of April 30, 2023 and Statement of Revenues and Expenses for the Period Ending April 30, 2023
- C. Assessment Receipt Schedule
- D. Approval of Check Register

X. Next Scheduled Meeting – 06/27/23 @ 4:00 p.m. @ Aberdeen Amenity Center

XI. Adjournment

FOURTH ORDER OF BUSINESS

A.

Fitness Patio Table Quotes Comparison

| Company | Amount |
|---------------------|--|
| Taylor & Associates | Expanded Metal Round - \$1524.90 Perforated Round - \$1771.58 Expanded Metal Bench - \$586.00 Perforated Bench \$679.58 Recycled Lumber Hexagon Table - \$942.90 Recyled Lumber Bench - \$1224.53 |
| Premier Polysteel | Perforated Round - \$1800.00 Perforated Square - \$1500.00 Perforated Square with back - \$1999.00 Perforated Oval - \$1389.00 |
| Uline | Metal Round - \$1220.00 Metal Square - \$1200.00 6' Rectangle - \$1150.00 8' Rectangle - \$1220.00 Hexagon Recycled Plastic Table - \$1295.00 6' Rectangle Recycled Plastic Table - \$1225.00 6' A Frame - \$1275.00 |



Taylor & Associates, Inc.

940 Opie Arnold Road
Limestone, TN 37681
Toll Free Direct: 855-734-3580

Quotation

| | |
|----------|---------|
| Date | Quote # |
| 5/9/2023 | 1728 |

| |
|--|
| Bill To |
| Aberdeen AP 110 Flower of Scotland Ave St Johns, FL 32259 904-217-0925 |

| |
|--|
| Ship To |
| Aberdeen Kate 110 Flower of Scotland Ave St Johns, FL 32259 904-217-0925 |

www.TaylorIncorporated.com

| P.O. Number | | Terms | Rep | Via |
|--|--------------|---|--------------|----------|
| | | See Terms Below | Renna Levert | Best Way |
| Quantity | Item Code | Description | Price Each | Amount |
| 4 | TA9551P1-099 | 4' Perforated Round Vinyl Plastisol Table, Free Standing, Black - Assembly Required | 1,771.58 | 7,086.32 |
| 2 | TA9473P7-099 | 6' Perforated Vinyl Plastisol Bench with Back, Surface Mount, Black - Assembly Required | 679.58 | 1,359.16 |
| Terms: Prepay via Company Check or Wire Transfer | | | | |
| Color - Black | | | | |
| Current Lead Time 12 to 14 weeks | | | | |
| 1 | S & H | Shipping & Handling Charges (Drop Ship Only) - Lift Gate, Inside Delivery, Heads Up Call are available for addition cost. | 1,352.40 | 1,352.40 |
| **Lift Gate Services Included** | | | | |

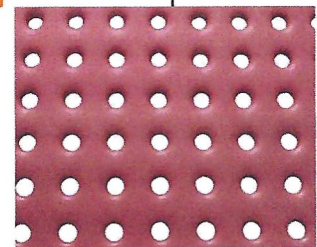

Sales Do Not Include Sales Tax, Purchaser Responsible For All Local, State & Use Tax Unless Otherwise Indicated. Quote Good For 30 Days. To process your order, please sign, date below and return via email.

Thank You So Very Much For Your Business!!
Approved By: _____

Date: _____

Sales Tax (0.0%)

\$0.00

Total

\$9,797.88



Taylor & Associates, Inc.

940 Opie Arnold Road
Limestone, TN 37681
Toll Free Direct: 855-734-3580

Quotation

| | |
|----------|---------|
| Date | Quote # |
| 5/9/2023 | 1729 |

| |
|--|
| Bill To |
| Aberdeen AP 110 Flower of Scotland Ave St Johns, FL 32259 904-217-0925 |

| |
|--|
| Ship To |
| Aberdeen Kate 110 Flower of Scotland Ave St Johns, FL 32259 904-217-0925 |

www.TaylorIncorporated.com

| P.O. Number | Terms | Rep | Via | |
|---|-----------------|--|------------|----------|
| | See Terms Below | Renna Levert | Best Way | |
| Quantity | Item Code | Description | Price Each | Amount |
| 4 | TA955101-099 | 4' Expanded Metal Round Vinyl Plastisol Table, Free Standing - Black, Assembly Required | 1,524.90 | 6,099.60 |
| 2 | TA934307-099 | 6' Expanded Metal Vinyl Plastisol, Bench with Back, Surface Mount - Black, Assembly Required | 586.95 | 1,173.90 |
| Terms: Prepay via Company Check or Wire Transfer Color - Black Current Lead Time 12 to 14 weeks | | | | |
| 1 | S & H | Shipping & Handling Charges (Drop Ship Only) - Lift Gate, Inside Delivery, Heads Up Call are available for addition cost. **Lift Gate Services Included** | 1,352.40 | 1,352.40 |

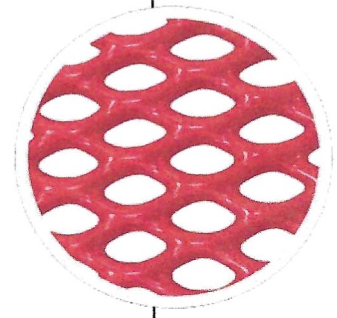
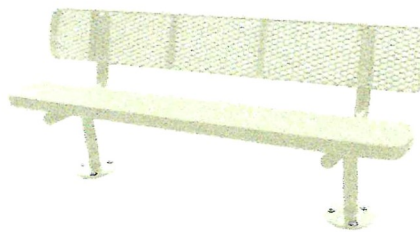

Sales Do Not Include Sales Tax, Purchaser Responsible For All Local, State & Use Tax Unless Otherwise Indicated. Quote Good For 30 Days. To process your order, please sign, date below and return via email.

Thank You So Very Much For Your Business!!
Approved By: _____

Date: _____

Sales Tax (0.0%)

\$0.00

Total

\$8,625.90



Taylor & Associates, Inc.

940 Opie Arnold Road
Limestone, TN 37681
Toll Free Direct: 855-734-3580

Quotation

| | |
|-----------|---------|
| Date | Quote # |
| 5/10/2023 | 1734 |

| |
|--|
| Bill To |
| Aberdeen AP 110 Flower of Scotland Ave St Johns, FL 32259 904-217-0925 |

| |
|--|
| Ship To |
| Aberdeen Kate 110 Flower of Scotland Ave St Johns, FL 32259 904-217-0925 |

www.TaylorIncorporated.com

| P.O. Number | | Terms | Rep | Via |
|-------------|-----------|---|--------------|----------|
| | | See Terms Below | Renna Levert | Best Way |
| Quantity | Item Code | Description | Price Each | Amount |
| 4 | TAFP1020 | Hex Picnic Table, Assembly Required | 942.90 | 3,771.60 |
| 2 | TAFP2040 | 6' Contour Bench, Above Ground, Assembly Required | 1,224.53 | 2,449.06 |
| 1 | Surcharge | Surcharge For Raw Material | 1,555.17 | 1,555.17 |
| | | Terms: Prepay via Company Check or Wire Transfer | | |
| | | Colors - TBD Tables Tops & Seats - Table Frame - Bench - Cedar with Black Surface Mounts Current Lead Time 5 to 6 weeks | | |
| 1 | S & H | Shipping & Handling Charges (Drop Ship Only) - Lift Gate, Inside Delivery, Heads Up Call are available for addition cost. | 907.50 | 907.50 |
| | | **Lift Gate Services Included** | | |



Sales Do Not Include Sales Tax, Purchaser Responsible For All Local, State & Use Tax Unless Otherwise Indicated. Quote Good For 30 Days. To process your order, please sign, date below and return via email.

Thank You So Very Much For Your Business!!

Approved By: _____

Date: _____

Sales Tax (0.0%)

\$0.00

Total

\$8,683.33



PREMIER POLYSTEEL
The Best Commercial Outdoor Furniture Available. Period.

Premier Polysteel
A Division of ADA Enterprises, Inc.
305 Enterprize Drive
PO Box 77
Northwood, IA 50459
Ph: 641-324-2750 Fax: 641-324-1092
Toll Free US & Canada: 877-746-3826

| Quote | |
|---------------------|-------------------------|
| Quote Number: 23326 | Quoted Date: 05/19/2023 |

| Quote To |
|--|
| Kate TRIVELPIECE 110 Flower of Scotland Ave SAINT JOHNS, FL 32259 United States of America |
| Ph: 904-421-0925 |

| |
|------------------------------|
| Expiration Date: 06/02/2023 |
| Terms: Due With Order |
| Ship Via: WorldWideExp |
| Salesperson Matthew Erickson |
| Reference: Ship to zip 32259 |

| Line | Quantity | Part Number/Description | Unit Price | Ext Price |
|------|----------|--|------------|------------|
| 001 | 1 ea | 955-1P1-093 4' Perf FS Rd Table-93 4' Perforated Metal Free Standing Round Table-Black Frame & Hunter Green Seats/Tops | \$1,800.00 | \$1,800.00 |

| Line | Quantity | Part Number/Description | Unit Price | Ext Price |
|------|----------|--|------------|------------|
| 002 | 1 ea | 926-1P1-093 4' Champ Perf FS Sq Tbl-93 4' Champion Perforated Metal Free Standing Square Table-Legs and Braces-Black; Seats and Tops-Hunter Green. | \$1,500.00 | \$1,500.00 |

| Line | Quantity | Part Number/Description | Unit Price | Ext Price |
|------|----------|---|------------|------------|
| 003 | 1 ea | 922-1P1-093 4'Champ Perf FS Sq Tbl w/BR-93 4' Champion Perforated Metal Free Standing Square With Back Rests Picnic Table- Legs/Brace-Black; Seat/Top-Hunter Green. | \$1,999.00 | \$1,999.00 |

| Line | Quantity | Part Number/Description | Unit Price | Ext Price |
|------|----------|--|------------|------------|
| 004 | 1 ea | 956-3P1 6' Perf FS Oval Table 6' Perforated Metal Free Standing Oval Table | \$1,389.00 | \$1,389.00 |

| Line | Quantity | Part Number/Description | Unit Price | Ext Price |
|------|----------|-------------------------|------------|------------|
| 005 | 1 ea | SHIP TO ZIP 32259 | \$1,296.00 | \$1,296.00 |



PREMIER POLYSTEEL
The Best Commercial Outdoor Furniture Available. Period.

Premier Polysteel
A Division of ADA Enterprises, Inc.
305 Enterprize Drive
PO Box 77
Northwood, IA 50459
Ph: 641-324-2750 Fax: 641-324-1092
Toll Free US & Canada: 877-746-3826

Quote

Quote Number: 23326 Quoted Date: 05/19/2023

Quote To
Kate
TRIVELPIECE
110 Flower of Scotland Ave
SAINT JOHNS, FL 32259
United States of America

Ph: 904-421-0925

Expiration Date: 06/02/2023
Terms: Due With Order
Ship Via: WorldWideExp
Salesperson Matthew Erickson
Reference: Ship to zip 32259

Terms: As stated above.

Total: \$7,984.00

Lead Time: 12 Weeks.

Freight: Please note this freight quote does not include a lift gate or special services. Should you need special services, let us know and we can adjust the quote as needed.

Warranty: All products manufactured by Premier Polysteel come with a 20 year limited warranty!

Cancellation Policy: Orders may be cancelled within 72 hours without penalty. Cancellation of order after 72 hours may be subject to restocking fees per our company terms.

All prices are net U.S. dollars. All local, state or other taxes, (if applicable) are the responsibility of the purchaser.

Freight note: If you need a lift gate and have not requested one, please notify us ASAP. Your freight costs and services will need to be adjusted accordingly.

** 20 yr. warranty
* No rust or mold
100% plastic coated
UV stabilizer*

4' ROUND PICNIC TABLE | FREE STANDING | PERFORATED METAL DESIGN

Home / Picnic Tables
4' Round Picnic Table | Free Standing | Perforated Metal Design

\$1,817



Comfortably seats eight adults. Umbrella hole is standard.

Seat & Top Color

Clear

Hunter Green

Legs Color

Black

- 1 + ADD TO CART

ADD TO QUOTE

Categories: Round Picnic Tables, Picnic Tables SKU: 955-1P1-093

Tag: 4 foot

Description Product Information

The 4' round picnic table with smooth perforated steel surfaces is a customer favorite! Perfect for easy dining, because beverages are less likely to tip! What's more, a thick layer of UV stable, mold-resistant plastisol completely coats the entire product. This coating protects it from harsh environmental elements. In addition, the free-standing (portable) legs are coated! Because there is no exposed metal, rust is never a problem. Because of this, we are able to offer a **20-year warranty!** Rust weakens the steel and shortens the life of outdoor furniture. Who wants that? Plus, because it's all coated metal, there will be no broken or sagging seats and the tabletop is so easy to clean!

Features:

- Easily clean with a power washer or hose using mild soap, then finish with a bleach-free disinfectant. Done!
- The smooth perforated steel surfaces have openings of approximately 3/8 inch. Beverages are less likely to tip on the smooth surface of coated perforated steel.
- All Premier Polysteel outdoor furniture is completely coated with a thick layer of UV stable, mold-resistant plastisol that protects the products and keeps them looking like new!



Smooth perforated steel surface.

4' SQUARE PICNIC TABLE | FREE STANDING | PERFORATED METAL DESIGN

[Home](#) / [Picnic Tables](#)
[4' Square Picnic Table | Free Standing | Perforated Metal Design](#)



\$1,555

Comfortably seats eight adults. Umbrella hole is standard.

Seat & Top Color Clear

Evergreen

Legs Color

Black

- 1 + [ADD TO CART](#)

[ADD TO QUOTE](#)

Categories: [Square Picnic Tables](#), [Picnic Tables](#) SKU: 926-1P1-096

Tag: [4 foot](#)

Description Product Information

| | |
|---------------------|---|
| Weight | 300 lbs |
| Shipping Dimensions | 50 × 60 × 8 in |
| Seat & Top Color | Black, Blue, Brown, Burgundy, Evergreen, Gray, Hunter Green, Ivory, Orange, Purple, Red, Yellow |
| Legs Color | Black, Blue, Brown, Burgundy, Evergreen, Gray, Hunter Green, Ivory, Orange, Purple, Red, Yellow |
| Footprint | 77 in x 77 in |
| Seating Capacity | 8 |
| Mount | Free Standing |
| Surface | Perforated Steel |

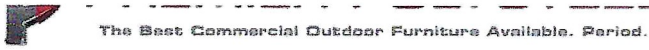

4' SQUARE PICNIC TABLE W/ BACKRESTS | FREE STANDING | PERFORATED METAL DESIGN

Home / Picnic Tables / 4' Square Picnic Table w/ Backrests | Free Standing | Perforated Metal Design

\$1,999



Comfortably seats eight adults. The center umbrella hole is standard.

Seat & Top Color

Legs Color

- 1 + ADD TO CART

ADD TO QUOTE

Categories: Square Picnic Tables, Picnic Tables SKU: 922-1P1-083

Tag: 4 foot

Description Product Information

This extremely durable and attractive picnic table with backrests will provide comfortable seating at its best! Family-friendly with smooth perforated metal surfaces and a walk-through design. No wonder it's a customer favorite! Perfect for an outdoor employee lunch space, or restaurant dining, and it also makes dining al fresco at home a relaxing way to end a busy day. Add in one of our [quality umbrellas](#) featuring Sunbrella fabric! Enjoy the cool shade and stay protected from direct sunlight.

Commercial Grade Picnic Table Benefits

- Comfortably seats up to eight adults
- Because it's all coated metal, there will be no broken or sagging seats and the tabletop is so easy to clean! It will look great for years to come!
- Easily clean with a power washer or hose using mild soap, then finish off with a bleach-free disinfectant. Done!
- Walk-through design for easy entry – therefore, no more bruised knees!
- The free-standing design features a center umbrella hole. See our [selection of umbrellas](#) to complete the look you want!



Smooth perforated steel surface.

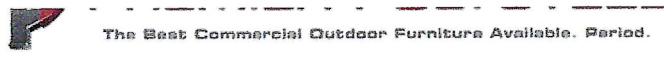

(041) 301-103

6' OVAL PICNIC TABLE | FREE STANDING | PERFORATED METAL DESIGN

Home / Picnic Tables / Oval Picnic Tables / 6' Oval Picnic Table | Free Standing | Perforated Metal Design

\$1,389



The gently curved seats comfortably accommodate six adults. Easy walk-through, no-tip design.

Seat & Top Color: Clear
Evergreen

Legs Color: Black

- 1 + ADD TO CART

ADD TO QUOTE

Categories: Picnic Tables, Oval Picnic Tables SKU: 956-3P1-096
Tag: 6 foot

Description Product Information

This family-friendly oval picnic table with smooth perforated steel surfaces is a customer favorite! Perfect for easy dining, because beverages are less likely to tip! Because of the wide frame design, this table won't tip even if everyone sits on the same side! What's more, a thick layer of UV stable, mold-resistant plastisol completely coats the entire product. This coating protects it from harsh environmental elements. In addition, the free-standing (portable) legs are coated! Because there is no exposed metal, rust is never a problem. Because of this, we are able to offer a 20-year warranty! Rust weakens the steel and shortens the life of outdoor furniture. Who wants that?



Smooth perforated steel surface.

Commercial Grade Picnic Table Benefits

- The gently curved seats comfortably accommodate up to six adults
- No-tip, walk-through design for worry-free dining
- Because it's all coated metal, there will be no broken or sagging seats and the tabletop is so easy to clean! It will look beautiful for years to come!
- Easily clean with a power washer or hose using mild soap, then finish with a bleach-free disinfectant. Done!
- The smooth surface of perforated steel has openings of approximately 3/8 inch. Beverages are less likely to tip on a flat surface.
- The center umbrella hole is standard on the oval picnic table. See our [selection of umbrellas](#) for the perfect match!



KIT-SM-S (L)

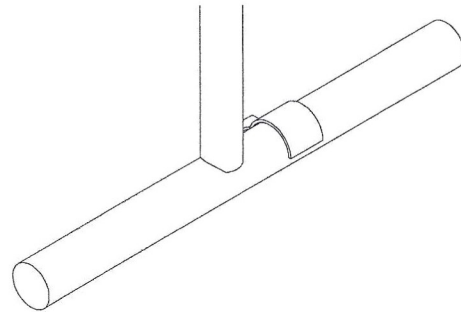
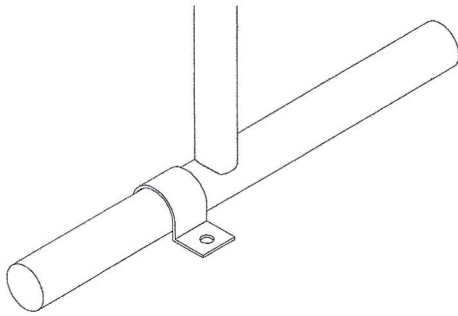

| Número De Pieza | Descripción | Cantidad |
|------------------|---|----------|
| Abrazadera-G (P) | Abrazadera Grande (Pequeño) | 2 |
| 516-047 | 3/8"x3-3/4" Anclaje de Concreto con Arandela y Tuerca | 2 |

- 1 Ponga el banco donde usted quiere y marque la posición de los tornillos de anclaje.
- 2 Perfore hoyo en concreto con una broca 3/8". El hoyo deber de estar 1-5/8" de hondo. (ver ilustracion 1)
- 3 Limpie los escombros del agujero y comprabe que hondo esta el hoyo.
- 4 Empuje el anclaje a través del los hoyos en el gancho (ver ilustracion 2)
- 5 Apriete la tuerca de 3 a 5 vueltas para ampliar el ancla (ver ilustraciones 3)

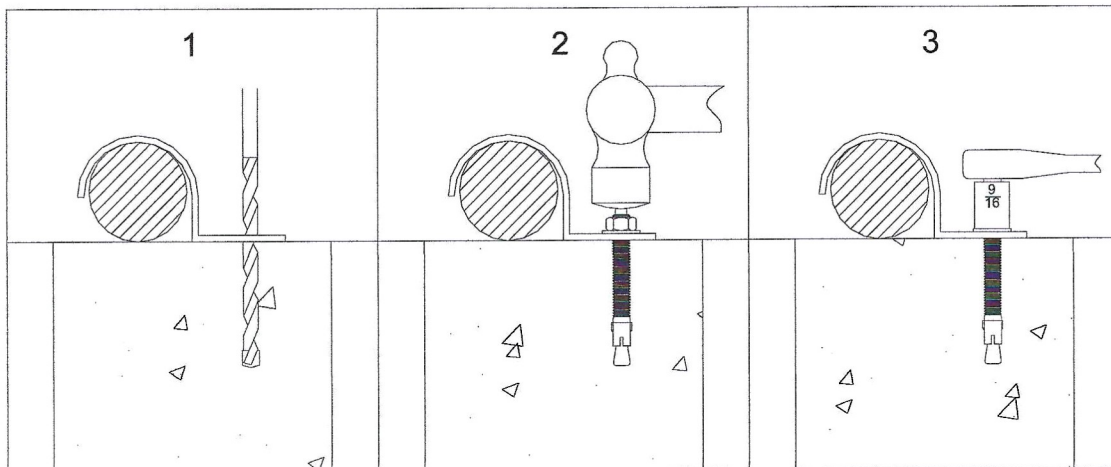

PREMIER POLYSTEEL

The Best Commercial Outdoor Furniture Available. Period.



METAL PICNIC TABLES



Enlarge & Video

Uline loves these! Attractive, rugged and built to last. Give your corporate office patio an upscale look.

- Thermoplastic coating withstands heat, cold and all weather elements. Rust free.
- High gloss, smooth surface allows for easy spray paint and graffiti removal.
- 9 gauge expanded metal with 2" black steel frame.
- Rounded corners for added safety.
- **ADA Picnic Tables** – Wheelchair access. Round and square tables have one less bench. Rectangle table has shorter benches.
- Mounting hardware included.
- [Umbrellas and Bases](#) available.

METAL PICNIC TABLES – IN STOCK SHIPS TODAY

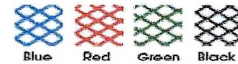

| MODEL NO. | DESCRIPTION | SIZE L x W x H | WT. (LBS.) | PRICE EACH | | ADD TO CART |
|-------------------------|--------------|----------------|------------|------------|---------|-------------------------------|
| | | | | 1 | 3+ | |
| H-9537 | 46" Square | 80 x 80 x 31" | 185 | \$1,200 | \$1,150 | Specify Color |
| H-10001 | 46" Round | 81 x 81 x 31" | 175 | 1,220 | 1,170 | Specify Color |
| H-10002 | 6' Rectangle | 72 x 61 x 31" | 145 | 1,150 | 1,100 | Specify Color |
| H-10003 | 8' Rectangle | 96 x 61 x 31" | 170 | 1,220 | 1,170 | Specify Color |

SHIPS SAME DAY FROM ULINE UNASSEMBLED VIA MOTOR FREIGHT

METAL PICNIC TABLES – CUSTOM COLORS



| MODEL NO. | DESCRIPTION | SIZE L x W x H | WT. (LBS.) | PRICE EACH | | ADD TO CART |
|------------------------|--------------|----------------|------------|------------|---------|-------------------------------|
| | | | | 1 | 3+ | |
| H-2126 | 46" Square | 80 x 80 x 31" | 185 | \$1,200 | \$1,150 | Specify Color |
| H-2127 | 46" Round | 81 x 81 x 31" | 175 | 1,220 | 1,170 | Specify Color |
| H-2128 | 6' Rectangle | 72 x 61 x 31" | 145 | 1,150 | 1,100 | Specify Color |
| H-2129 | 8' Rectangle | 96 x 61 x 31" | 170 | 1,220 | 1,170 | Specify Color |

DROP SHIPS FROM NC UNASSEMBLED VIA MOTOR FREIGHT

RECYCLED PLASTIC PICNIC TABLES



HEX

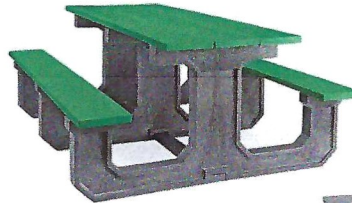

RECTANGLE

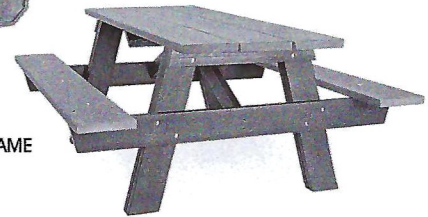

A-FRAME

[Enlarge & Video](#)

Virtually maintenance free! Recommended for warehouse patios, campgrounds, schools and parks.

- 100% recycled UV-protected plastic won't rot, splinter or crack. Withstands harsh weather.
- Natural-looking wood material never needs sanding, sealing, painting or staining.
- Durable 2" thick planks pre-drilled for easy assembly.
- Hex - Best selling picnic table.
- ADA Hex - Accommodates 1 wheelchair and 4 adults.
- Rectangle - Convenient walk-through design.
- A-Frame - Classic picnic table style.
- Mounting hardware sold separately.

RECYCLED PLASTIC PICNIC TABLES

Brown Cedar Green Gray

| MODEL NO. | DESCRIPTION | SIZE L x W x H | WT. (LBS.) | PRICE EACH | | ADD TO CART |
|------------------------|--------------|----------------|------------|------------|---------|-------------------------------|
| | | | | 1 | 3+ | |
| H-2560 | 46" Hex | 72 x 72 x 30" | 250 | \$1,295 | \$1,245 | Specify Color |
| H-6575 | 46" ADA Hex | 61 x 72 x 30" | 210 | 1,285 | 1,235 | Specify Color |
| H-2561 | 6' Rectangle | 72 x 61 x 30" | 310 | 1,225 | 1,175 | Specify Color |
| H-2562 | 8' Rectangle | 96 x 61 x 30" | 350 | 1,345 | 1,295 | Specify Color |
| H-2563 | 6' A-Frame | 72 x 61 x 30" | 260 | 1,275 | 1,225 | Specify Color |
| H-2564 | 8' A-Frame | 96 x 61 x 30" | 350 | 1,420 | 1,370 | Specify Color |

DROP SHIPS IN 2 DAYS FROM KS UNASSEMBLED VIA MOTOR FREIGHT

RECYCLED PLASTIC PICNIC TABLE MOUNTING HARDWARE

| MODEL NO. | DESCRIPTION | FITS | PRICE EACH | ADD TO CART |
|------------------------|-------------------|------------------------------|------------|--------------------------------------|
| H-2565 | Mounting Hardware | Rectangle Tables and Benches | \$28 | 1 <input type="button" value="ADD"/> |
| H-6681 | | Hex and A-Frame Tables | | 1 <input type="button" value="ADD"/> |

DROP SHIPS IN 2 DAYS

SIXTH ORDER OF BUSINESS

B.

RESOLUTION 2023-04

A RESOLUTION OF THE BOARD OF SUPERVISORS OF THE ABERDEEN COMMUNITY DEVELOPMENT DISTRICT APPROVING A PROPOSED BUDGET FOR FISCAL YEAR 2023/2024 AND SETTING A PUBLIC HEARING THEREON PURSUANT TO FLORIDA LAW; ADDRESSING TRANSMITTAL, POSTING AND PUBLICATION REQUIREMENTS; ADDRESSING SEVERABILITY; AND PROVIDING AN EFFECTIVE DATE.

WHEREAS, the District Manager has heretofore prepared and submitted to the Board of Supervisors (“**Board**”) of the Aberdeen Community Development District (“**District**”) prior to June 15, 2023, a proposed budget (“**Proposed Budget**”) for the fiscal year beginning October 1, 2023 and ending September 30, 2024 (“**Fiscal Year 2023/2024**”); and

WHEREAS, the Board has considered the Proposed Budget and desires to set the required public hearing thereon.

NOW, THEREFORE, BE IT RESOLVED BY THE BOARD OF SUPERVISORS OF THE ABERDEEN COMMUNITY DEVELOPMENT DISTRICT:

1. **PROPOSED BUDGET APPROVED.** The Proposed Budget prepared by the District Manager for Fiscal Year 2023/2024 attached hereto as **Exhibit A** is hereby approved as the basis for conducting a public hearing to adopt said Proposed Budget.

2. **SETTING A PUBLIC HEARING.** A public hearing on said approved Proposed Budget is hereby declared and set for the following date, hour and location:

DATE: _____, 2023

HOUR: _____

LOCATION: _____

3. **TRANSMITTAL OF PROPOSED BUDGET TO LOCAL GENERAL PURPOSE GOVERNMENT.** The District Manager is hereby directed to submit a copy of the Proposed Budget to St. Johns County at least 60 days prior to the hearing set above.

4. **POSTING OF PROPOSED BUDGET.** In accordance with Section 189.016, *Florida Statutes*, the District’s Secretary is further directed to post the approved Proposed Budget on the District’s website at least two days before the budget hearing date as set forth in Section 2, and shall remain on the website for at least 45 days.

5. **PUBLICATION OF NOTICE.** Notice of this public hearing shall be published in the manner prescribed in Florida law.

6. **SEVERABILITY.** The invalidity or unenforceability of any one or more provisions of this Resolution shall not affect the validity or enforceability of the remaining portions of this Resolution, or any part thereof.

7. **EFFECTIVE DATE.** This Resolution shall take effect immediately upon adoption.

PASSED AND ADOPTED THIS 30TH DAY OF MAY, 2023.

ATTEST:

**ABERDEEN COMMUNITY DEVELOPMENT
DISTRICT**

Secretary / Assistant Secretary

Chair/Vice Chair, Board of Supervisors

Exhibit A: Proposed Budget

SEVENTH ORDER OF BUSINESS

C.



April 21, 2023

Aberdeen Community Development District
Attn: Sarah Sweeting, Recording Secretary
475 West Town Place, Ste. 114
St. Augustine, FL 32092

Dear Ms. Sweeting:

In response to your request regarding Section 190.006(3)(a)(2)(d), Florida Statutes, the following information is applicable for:

Aberdeen CDD

3656 registered voters in St. Johns County

This number is based on the streets within the legal description on file with this office as of April 15, 2023.

Please contact us if we may be of further assistance.

Sincerely,

A handwritten signature in blue ink that reads "Vicky Oakes".

Vicky C. Oakes
Supervisor of Elections

VO/db

E.

Aberdeen CDD GM/LD Agenda
May 30, 2023

GM Update:

➤ Facility Update:

- Pool bathroom renovations completed.
- Pool slide black gate repainted.
- All fitness center equipment in working order.
- New ADA compliant pool lifts have been installed.
- New yellow fly repellent balls have been placed around the pool deck.
- New grill propane gauges have been installed and new grill deposit/ form in place for residents.
- New safety barrier chains were replaced in front of pool slide.
- Front Cabana and entrance area pressure washed.
- Swim Team blocks installed for season.

Lifestyle Events Recap:

- Swim team practices are currently being held Tuesday-Thursday 4:30-6:30pm, morning practices will begin this week with additional 7:30-8:30am practice.
- 50+ Potluck Grillin & Chillin event held on 5/12/23 (photos attached.)
- Schools Out Movie Night & Ice Cream Social held on 5/26/23.
- Memorial Day Pool Party with food trucks and DJ was held on 5/29/23.

Lifestyle Upcoming Events:

- Safety First will be offering a Babysitters Safety Class on 6/1/23.
- 50+ Social to be held on 6/9/23 in the Social Hall.
- Swim Team will hold 1 home meet in the month of June on June 10th.
- We have added new Zumba and water Zumba classes beginning in June.
- Swim lessons will be offered from Elite Amenities and Safety First starting in June.
- Kat Dance will be offering a Summer Dance program for June and July.

MAY ABERDEEN FACILITY UPDATE



POOL BATHROOM COMPLETED

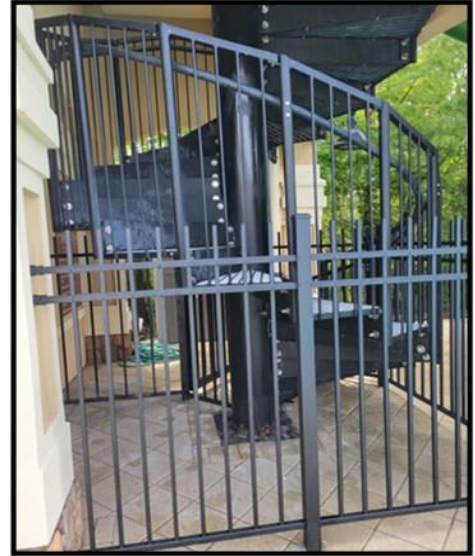

SLIDE GATE PAINTED



NEW ADA CHAIRS INSTALLED



YELLOW FLY REPELLANTS

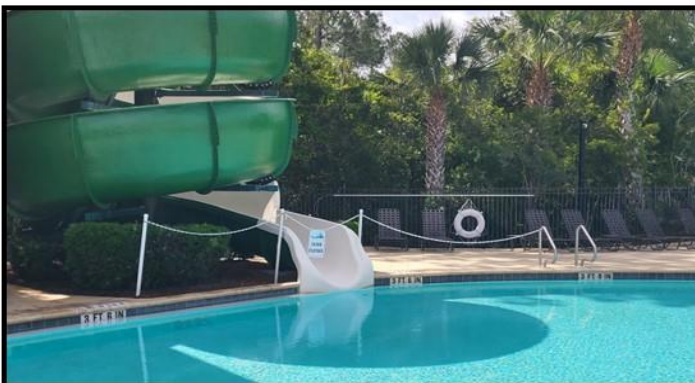

SLIDE BARRIER CHAINS REPLACED



SWIM TEAM BLOCKS INSTALLED



50+ Club



NINTH ORDER OF BUSINESS

A.

MINUTES OF MEETING
ABERDEEN
COMMUNITY DEVELOPMENT DISTRICT

The regular meeting of the Board of Supervisors of the Aberdeen Community Development District was held Tuesday, April 25, 2023 at 4:00 p.m. at the Aberdeen Amenity Center, 110 Flower of Scotland Avenue, St. Johns, Florida.

Present and constituting a quorum were:

| | |
|-----------------|---------------|
| Lauren Egleston | Chairperson |
| Paul Fogel | Vice Chairman |
| Angela Andrews | Supervisor |
| Thomas Marmo | Supervisor |
| Susie Clarke | Supervisor |

Also present were:

| | |
|------------------|--------------------------------|
| Jim Oliver | District Manager |
| Wes Haber | District Counsel |
| George Katsaras | District Engineer by telephone |
| Kate Trivelpiece | FirstService Residential |
| Jay Parker | First Service Residential |
| Howard McGaffney | GMS |

The following is a summary of the actions taken at the April 25, 2023 meeting.

FIRST ORDER OF BUSINESS

Roll Call

Mr. Oliver called the meeting to order at 4:00 p.m. and called the roll.

SECOND ORDER OF BUSINESS

Public Comments

Ms. Sang I would like the board to discuss adding a pickleball court.

THIRD ORDER OF BUSINESS

Consideration of Proposals

A. Slide Quotes

Ms. Trivelpiece gave an overview of the proposal to replace the slide.

On MOTION by Ms. Andrews seconded by Mr. Fogel with all in favor the proposal from Playmore in the amount of \$6,831.50 was approved subject to the \$261.50 tax being removed.

B. Bike Rack Proposals

This item tabled.

C. Furniture Proposals for Fitness Center Area

This item tabled.

D. ADA Pool Lift Proposals

Ms. Trivelpiece gave an overview of the proposals to replace the ADA compliant pool lifts.

On MOTION by Ms. Egleston seconded by Mr. Marmo with all in favor the chair was authorized to work with staff on the purchase and installation of two ADA compliant pool lift chairs in an amount not to exceed \$13,000.

FOURTH ORDER OF BUSINESS

Presentation of Preliminary Fiscal Year 2024 Budget

Mr. Oliver stated next is discussion of a preliminary fiscal year 2024 budget. I'm passing out a very preliminary budget that is subject to great change. The caveats I want to talk about, on page 2 are two tables and the top table shows what the assessment increase, throw that out. On the front page we have a line item called, carry forward surplus in the revenue section and last year we had carry forward surplus of \$125,000 to help keep assessments low, right now we don't have a number in there. Some of the other things I want to point out is toward the bottom if you look at the amenity center section the last section where it says management contracts, I have reached out to Lucy and I'm waiting on their input and what the budget numbers will be for FY24. You are on track to have a modest surplus at the end of this year without considering the \$125,000 I spoke of earlier. I think you will be in great shape for next year. I need to work on the budget and we will bring the proposed budget to your May meeting, approve a proposed budget and set the public hearing to be held in August so you can refine the budget over the next couple months. I am going to be on vacation on May 23rd and if we could reschedule this meeting to May 30th,

otherwise I would have to send someone else to cover it and I would like to be here for anything to do with the budget if you are comfortable with that.

On MOTION by Ms. Andrews seconded by Ms. Clarke with all in favor the May 23 meeting was moved to May 30, 2023 at 6:00 p.m.

Mr. Oliver stated when we bring the proposed budget it will be the full 14 pages with all the line items and really dig into it at that point. Don't circulate this because it is not reality at this point. I will circulate the proposed budget in advance of the meeting and if you have comments, reach out and call me if you want to discuss it before the meeting.

FIFTH ORDER OF BUSINESS

Staff Reports

A. Attorney

Mr. Haber stated my office is working on updated policies related to suspension and termination of the right to use the amenity facilities that I will present at a future meeting.

B. Engineer

Mr. Oliver stated I know you were recently onsite with Jay and inspected a lot that had drainage problems with the fence that was flush to the ground. Can you give an overview of that?

Mr. Katsaras stated Jay looked at that one, I have not. We were going to meet him out there later this week. I think Jay has already looked at it.

Mr. Parker stated I met with the resident and his fence was too low to the ground and there was a bunch of dirt pushed up against his fence and grass grew on it. Everybody's fence is about a foot off the ground except for his. I suggested he dig under the fence and clear it out and that should help and if not then reach back out to us. This is the house on Shetland. The house on Mahogany has a different issue. He is next to a preserve and he was trying to see if the landscapers could go in and clear out some of the vegetation and dig a trench. I asked George to meet me out there so we can find a way to clear that out.

Ms. Egleston asked do we allow residents to go back a foot and a half off their property line into the preserve and clear? He will be responsible for that not us.

Mr. Parker stated that is what I was going to talk about with George. Nobody took care of this and all the stuff flowed from the preserve to his property. There are a lot of bushes that grew up back there. I don't know if he would be responsible for cleaning that or us.

Mr. Haber stated if there are truly preserves subject to a conservation easement, I'm not aware of a general policy that allows people go five feet into it. I would say we need to be careful about that. I would need to look at the actual documents. If it says buffer then it is not conservation property, it is not subject to a conservation easement and it may be entitled to be cleared. We want to be very careful with this or giving any direction to clear preservation property. As far as vegetation growing onto his property, in Florida you have every right to clear your property or if a branch is overhanging your property you can cut the branch up to your property line. If what we are talking about is doing work on the resident's property that you could do that but you also have a right to say it is your property, when you saw it growing towards your property you have the obligation to fix that. If you believe that there is something we should be doing on our end let us know. I'm not suggesting that you not try to cooperate with your residents but at the same time I don't think you want to be in the business of in every instance that landscaping from CDD property may have gone onto resident's property, the resident has the right to take care of their own property.

C. Manager

There being none, the next item followed.

D. Operation Manager

Mr. Parker stated the fountain is being built up there, they should have that in two weeks. We did have a water filtration put inside the gym and it is running beautifully.

E. Amenity Center Manager - Report

Ms. Trivelpiece reviewed the facility update, past and upcoming lifestyle events and stated First Service Residential runs an annual quality assurance inspection. We came in April 10th and basically go over everything. I have a report that I will send to all of you and you may want to discuss that at the next meeting. First Service had a quarterly meeting last Friday and we were

scored 4.06 as well as most improved in safety for Aberdeen and that was based off last years and this year.

SIXTH ORDER OF BUSINESS

Supervisors Requests and Public Comments

Additional items: Security of new outdoor furniture by fitness center, staging and communication of construction project on Longleaf, irrigation system breaks from cars driving across sidewalks and grass by school pickup and drop off, likelihood of survival and cost of transplanting palms, signage on JEA property, possible eblast about parking on grassed areas, possible areas for pickleball courts.

SEVENTH ORDER OF BUSINESS

Approval of Consent Agenda

- A. Approval of the Minutes of the March 28, 2023 Meeting**
- B. Balance Sheet as of March 31, 2023 and Statement of Revenues and Expenses for the Period Ending March 31, 2023**
- C. Assessment Receipt Schedule**
- D. Approval of Check Register**

On MOTION by Mr. Egleston seconded by Mr. Marmo with all in favor the consent agenda items were approved.

EIGHTH ORDER OF BUSINESS

Next Scheduled Meeting – 05/23/23 @ 6:00 p.m. @ Aberdeen Amenity Center

Mr. Oliver stated the next scheduled meeting will be held May 30, 2023 at 6:00 p.m.

On MOTION by Mr. Fogel seconded by Ms. Clarke with all in favor the meeting adjourned at 5:07 p.m.

Secretary/Assistant Secretary

Chairman/Vice Chairman

B.

Aberdeen

Community Development District

Unaudited Financial Reporting

April 30, 2023

Aberdeen
Community Development District
Combined Balance Sheet

April 30, 2023

Governmental Fund Types

| | General | Debt Service | Capital Reserve | Capital Projects | Totals (Memorandum Only) |
|--|------------------|-------------------------|----------------------------|-----------------------------|-------------------------------------|
| Assets: | | | | | |
| Cash | \$675,208 | --- | \$442,713 | --- | \$1,117,921 |
| Investments: | | | | | |
| Operations | | | | | |
| Custody Account | \$56,090 | --- | --- | --- | \$56,090 |
| State Board of Administration - General Fund | \$51,160 | --- | --- | --- | \$51,160 |
| State Board of Administration - Capital Reserve | --- | --- | \$164,925 | --- | \$164,925 |
| State Board of Administration - Renewal & Rplcmt | --- | --- | \$108,845 | --- | \$108,845 |
| Series 2005/2020A | | | | | |
| Reserve A1 | --- | \$378,625 | --- | --- | \$378,625 |
| Interest A1 | --- | \$6,774 | --- | --- | \$6,774 |
| Prepayment A1 | --- | \$4,445 | --- | --- | \$4,445 |
| Revenue | --- | \$1,931,405 | --- | --- | \$1,931,405 |
| Reserve A2 | --- | \$218,250 | --- | --- | \$218,250 |
| Interest A2 | --- | \$3,904 | --- | --- | \$3,904 |
| Prepayment A2 | --- | \$2,679 | --- | --- | \$2,679 |
| General Redemption | --- | \$34,188 | --- | --- | \$34,188 |
| Series 2018 | | | | | |
| Reserve | --- | \$67,138 | --- | --- | \$67,138 |
| Revenue | --- | \$136,944 | --- | --- | \$136,944 |
| Prepayment | --- | \$128 | --- | --- | \$128 |
| Redemption | --- | \$1,538 | --- | --- | \$1,538 |
| Construction | --- | --- | --- | \$48,429 | \$48,429 |
| Due from Other | \$140 | --- | --- | --- | \$140 |
| Prepaid Expenses | \$874 | --- | --- | --- | \$874 |
| Assessments Receivable | \$14,009 | \$25,628 | --- | --- | \$39,637 |
| Total Assets | \$797,481 | \$2,811,647 | \$716,483 | \$48,429 | \$4,374,039 |
| Liabilities: | | | | | |
| Accounts Payable | \$71,671 | --- | --- | --- | \$71,671 |
| Fund Balances: | | | | | |
| Restricted for Debt Service | --- | \$2,811,647 | --- | --- | \$2,811,647 |
| Restricted for Capital Projects | --- | --- | --- | \$48,429 | \$48,429 |
| Nonspendable | \$874 | --- | --- | --- | \$874 |
| Assigned | \$125,000 | --- | --- | --- | \$125,000 |
| Unassigned | \$599,936 | --- | \$716,483 | --- | \$1,316,419 |
| Total Liabilities and Fund Equity | \$797,481 | \$2,811,647 | \$716,483 | \$48,429 | \$4,374,039 |

Aberdeen
Community Development District
General Fund

Statement of Revenues & Expenditures
for the period ending
April 30, 2023

| | ADOPTED BUDGET | PRORATED BUDGET Thru 04/30/23 | ACTUAL Thru 04/30/23 | VARIANCE |
|------------------------|--------------------|----------------------------------|-------------------------|------------------|
| REVENUES: | | | | |
| Assessments - Tax Roll | \$1,138,335 | \$1,138,335 | \$1,133,081 | (\$5,253) |
| Interest | \$200 | \$200 | \$3,533 | \$3,333 |
| Amenities Revenue/Misc | \$25,000 | \$14,583 | \$12,467 | (\$2,116) |
| TOTAL REVENUES | \$1,163,535 | \$1,153,118 | \$1,149,082 | (\$4,036) |

EXPENDITURES:

Administrative

| | | | | |
|--|------------------|------------------|-----------------|-----------------|
| Supervisor Fees | \$12,000 | \$7,000 | \$6,000 | \$1,000 |
| FICA Expense | \$918 | \$536 | \$459 | \$77 |
| Assessment Administration | \$5,000 | \$5,000 | \$5,000 | \$0 |
| Engineering Fees | \$7,000 | \$4,083 | \$2,440 | \$1,644 |
| Arbitrage | \$1,200 | \$700 | \$0 | \$700 |
| Dissemination Agent | \$7,800 | \$4,550 | \$4,333 | \$217 |
| Impact Fee Administration | \$10,000 | \$5,833 | \$0 | \$5,833 |
| Attorney Fees | \$37,000 | \$21,583 | \$10,933 | \$10,651 |
| Annual Audit | \$3,650 | \$2,129 | \$0 | \$2,129 |
| Trustee Fees | \$14,500 | \$6,853 | \$6,853 | \$0 |
| Management Fees | \$52,796 | \$30,798 | \$30,798 | \$0 |
| Information Technology | \$1,800 | \$1,050 | \$1,050 | \$0 |
| Travel and Per Diem | \$300 | \$175 | \$0 | \$175 |
| Telephone | \$700 | \$408 | \$268 | \$141 |
| Postage | \$2,000 | \$1,167 | \$482 | \$684 |
| Printing and Binding | \$2,000 | \$1,167 | \$389 | \$777 |
| Insurance | \$12,408 | \$12,408 | \$11,116 | \$1,292 |
| Legal Advertising | \$2,000 | \$1,167 | \$339 | \$828 |
| Other Current Charges | \$1,000 | \$583 | \$10 | \$573 |
| Office Supplies | \$250 | \$146 | \$203 | (\$58) |
| Dues, Licenses & Subscriptions | \$175 | \$175 | \$175 | \$0 |
| TOTAL ADMINISTRATIVE EXPENDITURES | \$174,497 | \$107,511 | \$80,848 | \$26,663 |

Amenity Center

| | | | | |
|--------------------------|----------|----------|----------|-----------|
| Insurance | \$41,825 | \$41,825 | \$38,674 | \$3,151 |
| Repairs & Replacements | \$45,000 | \$26,250 | \$35,764 | (\$9,514) |
| Special Events | \$18,500 | \$18,500 | \$21,826 | (\$3,326) |
| Staff Uniforms | \$1,500 | \$875 | \$0 | \$875 |
| Recreational Supplies | \$1,800 | \$1,050 | \$0 | \$1,050 |
| Recreational Passes | \$1,600 | \$933 | \$696 | \$238 |
| Other Current Charges | \$1,000 | \$583 | \$15 | \$568 |
| Permit Fees | \$2,200 | \$2,200 | \$3,040 | (\$840) |
| Office Supplies | \$3,150 | \$1,838 | \$1,600 | \$238 |
| Credit Card Machine Fees | \$450 | \$450 | \$544 | (\$94) |
| Pest Control | \$3,000 | \$1,750 | \$1,400 | \$350 |
| Utilities | | | | |
| Water & Sewer | \$20,000 | \$11,667 | \$7,665 | \$4,001 |
| Electric | \$40,000 | \$23,333 | \$24,038 | (\$705) |
| Cable/Internet/Phone | \$12,500 | \$7,292 | \$9,024 | (\$1,732) |

Aberdeen

Community Development District General Fund

Statement of Revenues & Expenditures
for the period ending
April 30, 2023

| | ADOPTED BUDGET | PRORATED BUDGET Thru 04/30/23 | ACTUAL Thru 04/30/23 | VARIANCE |
|--|--------------------|----------------------------------|-------------------------|-----------------|
| <u>Management Contracts</u> | | | | |
| Field Operations Management - FirstService | \$72,440 | \$42,257 | \$47,378 | (\$5,121) |
| Pool Attendants/Lifeguards - Elite LifeGuard | \$50,000 | \$29,167 | \$14,625 | \$14,542 |
| Facility Management - FirstService | \$99,441 | \$58,007 | \$61,038 | (\$3,030) |
| Pool Maintenance/Supplies - FirstService | \$28,210 | \$16,456 | \$12,956 | \$3,500 |
| Janitorial Services - FirstService | \$54,240 | \$31,640 | \$19,942 | \$11,698 |
| General Facility Maintenance - FirstService | \$40,560 | \$23,660 | \$32,069 | (\$8,409) |
| Resident Services Coordinator- FirstService | \$49,040 | \$28,607 | \$31,842 | (\$3,235) |
| Management Fee - FirstService | \$12,900 | \$7,525 | \$7,525 | \$0 |
| Pool Chemicals - Poolsure | \$30,000 | \$17,500 | \$17,381 | \$119 |
| Refuse Service | \$12,000 | \$7,000 | \$7,252 | (\$252) |
| Security | \$17,800 | \$10,383 | \$10,371 | \$12 |
| Website | \$1,800 | \$1,050 | \$1,050 | \$0 |
| Holiday Decorations | \$12,000 | \$8,827 | \$8,827 | \$0 |
| Subscriptions | \$2,988 | \$1,743 | \$2,042 | (\$299) |
| TOTAL AMENITY CENTER EXPENDITURES | \$675,944 | \$422,367 | \$418,583 | \$3,783 |
| <u>Grounds Maintenance</u> | | | | |
| Electric | \$11,000 | \$6,417 | \$6,775 | (\$358) |
| Streetlighting | \$33,000 | \$19,250 | \$20,724 | (\$1,474) |
| Lake Maintenance | \$33,000 | \$19,250 | \$19,092 | \$158 |
| Landscape Maintenance | \$258,568 | \$150,832 | \$150,832 | (\$0) |
| Common Area Maintenance | \$30,525 | \$17,806 | \$6,464 | \$11,342 |
| Reuse Water | \$55,000 | \$32,083 | \$18,106 | \$13,978 |
| Miscellaneous | \$7,000 | \$4,083 | \$541 | \$3,543 |
| Irrigation Repairs | \$10,000 | \$5,833 | \$500 | \$5,333 |
| TOTAL GROUNDS MAINT. EXPENDITURES | \$438,093 | \$255,555 | \$223,033 | \$32,522 |
| TOTAL EXPENDITURES | \$1,288,535 | \$785,432 | \$722,464 | \$62,969 |
| EXCESS REVENUES/(EXPENSES) | (\$125,000) | | \$426,618 | |
| NET CHANGE IN FUND BALANCE | (\$125,000) | | \$426,618 | |
| Fund Balance - Beginning | \$125,000 | | \$299,192 | |
| Fund Balance - Ending | <u>\$0</u> | | <u>\$725,810</u> | |

Aberdeen Community Development District

General Fund

Statement of Revenues & Expenditures

Fiscal Year 2023

| | Oct | Nov | Dec | Jan | Feb | Mar | Apr | May | Jun | Jul | Aug | Sept | Total |
|-----------------------|----------------|-----------------|------------------|------------------|-----------------|----------------|-----------------|------------|------------|------------|------------|------------|--------------------|
| Assessment - Tax Roll | \$0 | \$64,746 | \$261,183 | \$744,254 | \$43,545 | \$4,467 | \$14,887 | \$0 | \$0 | \$0 | \$0 | \$0 | \$1,133,081 |
| Interest | \$116 | \$145 | \$127 | \$347 | \$493 | \$1,970 | \$336 | \$0 | \$0 | \$0 | \$0 | \$0 | \$3,533 |
| Amenities Revenue | \$2,079 | \$2,469 | \$100 | \$2,126 | \$1,394 | \$2,290 | \$2,009 | \$0 | \$0 | \$0 | \$0 | \$0 | \$12,467 |
| TOTAL REVENUES | \$2,194 | \$67,360 | \$261,410 | \$746,727 | \$45,432 | \$8,726 | \$17,231 | \$0 | \$0 | \$0 | \$0 | \$0 | \$1,149,082 |

EXPENDITURES:

Administrative

| | | | | | | | | | | | | | |
|--|-----------------|-----------------|----------------|----------------|----------------|-----------------|----------------|------------|------------|------------|------------|------------|-----------------|
| Supervisor Fees | \$1,200 | \$600 | \$200 | \$1,200 | \$0 | \$1,800 | \$1,000 | \$0 | \$0 | \$0 | \$0 | \$0 | \$6,000 |
| FICA Expense | \$92 | \$46 | \$15 | \$92 | \$0 | \$138 | \$77 | \$0 | \$0 | \$0 | \$0 | \$0 | \$459 |
| Assessment Administration | \$5,000 | \$0 | \$0 | \$0 | \$0 | \$0 | \$0 | \$0 | \$0 | \$0 | \$0 | \$0 | \$5,000 |
| Engineering Fees | \$1,795 | \$0 | \$0 | \$0 | \$323 | \$323 | \$0 | \$0 | \$0 | \$0 | \$0 | \$0 | \$2,440 |
| Arbitrage | \$0 | \$0 | \$0 | \$0 | \$0 | \$0 | \$0 | \$0 | \$0 | \$0 | \$0 | \$0 | \$0 |
| Dissemination Agent | \$583 | \$583 | \$583 | \$583 | \$583 | \$583 | \$833 | \$0 | \$0 | \$0 | \$0 | \$0 | \$4,333 |
| Impact Fee Administration | \$0 | \$0 | \$0 | \$0 | \$0 | \$0 | \$0 | \$0 | \$0 | \$0 | \$0 | \$0 | \$0 |
| Attorney Fees | \$2,738 | \$1,500 | \$348 | \$1,716 | \$1,867 | \$2,764 | \$0 | \$0 | \$0 | \$0 | \$0 | \$0 | \$10,933 |
| Annual Audit | \$0 | \$0 | \$0 | \$0 | \$0 | \$0 | \$0 | \$0 | \$0 | \$0 | \$0 | \$0 | \$0 |
| Trustee Fees | \$3,438 | \$3,416 | \$0 | \$0 | \$0 | \$0 | \$0 | \$0 | \$0 | \$0 | \$0 | \$0 | \$6,853 |
| Management Fees | \$4,400 | \$4,400 | \$4,400 | \$4,400 | \$4,400 | \$4,400 | \$4,400 | \$0 | \$0 | \$0 | \$0 | \$0 | \$30,798 |
| Information Technology | \$150 | \$150 | \$150 | \$150 | \$150 | \$150 | \$150 | \$0 | \$0 | \$0 | \$0 | \$0 | \$1,050 |
| Travel and Per Diem | \$0 | \$0 | \$0 | \$0 | \$0 | \$0 | \$0 | \$0 | \$0 | \$0 | \$0 | \$0 | \$0 |
| Telephone | \$79 | \$34 | \$33 | \$19 | \$8 | \$34 | \$60 | \$0 | \$0 | \$0 | \$0 | \$0 | \$268 |
| Postage | \$16 | \$16 | \$336 | \$45 | \$16 | \$9 | \$44 | \$0 | \$0 | \$0 | \$0 | \$0 | \$482 |
| Printing and Binding | \$113 | \$96 | \$57 | \$17 | \$43 | \$31 | \$32 | \$0 | \$0 | \$0 | \$0 | \$0 | \$389 |
| Insurance | \$11,116 | \$0 | \$0 | \$0 | \$0 | \$0 | \$0 | \$0 | \$0 | \$0 | \$0 | \$0 | \$11,116 |
| Legal Advertising | \$68 | \$68 | \$0 | \$68 | \$68 | \$67 | \$0 | \$0 | \$0 | \$0 | \$0 | \$0 | \$339 |
| Other Current Charges | \$0 | \$0 | \$0 | \$10 | \$0 | \$0 | \$0 | \$0 | \$0 | \$0 | \$0 | \$0 | \$10 |
| Office Supplies | \$137 | \$63 | \$1 | \$1 | \$1 | \$0 | \$1 | \$0 | \$0 | \$0 | \$0 | \$0 | \$203 |
| Dues, Licenses & Subscriptions | \$175 | \$0 | \$0 | \$0 | \$0 | \$0 | \$0 | \$0 | \$0 | \$0 | \$0 | \$0 | \$175 |
| TOTAL ADMINISTRATIVE EXPENDITURES | \$31,098 | \$10,970 | \$6,124 | \$8,301 | \$7,459 | \$10,299 | \$6,596 | \$0 | \$0 | \$0 | \$0 | \$0 | \$80,848 |

Amenity Center

| | | | | | | | | | | | | | |
|--------------------------|----------|---------|---------|---------|---------|----------|---------|-----|-----|-----|-----|-----|----------|
| Insurance | \$38,674 | \$0 | \$0 | \$0 | \$0 | \$0 | \$0 | \$0 | \$0 | \$0 | \$0 | \$0 | \$38,674 |
| Repairs & Replacements | \$4,719 | \$5,095 | \$5,352 | \$2,701 | \$1,331 | \$10,713 | \$5,853 | \$0 | \$0 | \$0 | \$0 | \$0 | \$35,764 |
| Special Events | \$5,447 | \$4,170 | \$1,909 | \$3,165 | \$2,896 | \$2,833 | \$1,407 | \$0 | \$0 | \$0 | \$0 | \$0 | \$21,826 |
| Staff Uniforms | \$0 | \$0 | \$0 | \$0 | \$0 | \$0 | \$0 | \$0 | \$0 | \$0 | \$0 | \$0 | \$0 |
| Recreational Supplies | \$0 | \$0 | \$0 | \$0 | \$0 | \$0 | \$0 | \$0 | \$0 | \$0 | \$0 | \$0 | \$0 |
| Recreational Passes | \$0 | \$0 | \$696 | \$0 | \$0 | \$0 | \$0 | \$0 | \$0 | \$0 | \$0 | \$0 | \$696 |
| Other Current Charges | \$0 | \$0 | \$0 | \$0 | \$0 | \$0 | \$15 | \$0 | \$0 | \$0 | \$0 | \$0 | \$15 |
| Permit Fees | \$0 | \$0 | \$3,040 | \$0 | \$0 | \$0 | \$0 | \$0 | \$0 | \$0 | \$0 | \$0 | \$3,040 |
| Office Supplies | \$15 | \$765 | \$84 | \$143 | \$394 | \$67 | \$133 | \$0 | \$0 | \$0 | \$0 | \$0 | \$1,600 |
| Credit Card Machine Fees | \$66 | \$46 | \$80 | \$28 | \$78 | \$51 | \$195 | \$0 | \$0 | \$0 | \$0 | \$0 | \$544 |
| Pest Control | \$189 | \$189 | \$189 | \$208 | \$208 | \$208 | \$208 | \$0 | \$0 | \$0 | \$0 | \$0 | \$1,400 |
| Utilities | | | | | | | | | | | | | |
| Water & Sewer | \$710 | \$1,419 | \$1,319 | \$1,260 | \$1,001 | \$1,012 | \$945 | \$0 | \$0 | \$0 | \$0 | \$0 | \$7,665 |
| Electric | \$4,785 | \$3,578 | \$2,656 | \$2,791 | \$3,766 | \$3,273 | \$3,189 | \$0 | \$0 | \$0 | \$0 | \$0 | \$24,038 |
| Cable/Internet/Phone | \$1,166 | \$1,219 | \$1,248 | \$1,277 | \$1,308 | \$1,339 | \$1,467 | \$0 | \$0 | \$0 | \$0 | \$0 | \$9,024 |

Management Contracts

Aberdeen
Community Development District
Debt Service Fund-Series 2005 and Series 2020A1 and A2
Statement of Revenues & Expenditures
For the Period Ending
April 30, 2023

| | ADOPTED BUDGET | PRORATED Thru 04/30/23 | ACTUAL Thru 04/30/23 | VARIANCE |
|--|-------------------|---------------------------|-------------------------|----------|
|--|-------------------|---------------------------|-------------------------|----------|

Revenues:

| | | | | |
|--------------------------------|--------------------|--------------------|-----------------------|-----------------|
| Special Assessments - Tax Roll | \$1,947,438 | \$1,947,438 | \$1,938,507 | (\$8,931) |
| Interest Income | \$1,000 | \$1,000 | \$30,662 | \$29,662 |
| Total Revenues | \$1,948,438 | \$1,948,438 | \$1,969,169.17 | \$20,731 |

Expenditures

2020 A1

| | | | | |
|---------------|-----------|-----------|-----------|-----|
| Interest 11/1 | \$317,419 | \$317,419 | \$317,419 | \$0 |
| Interest 5/1 | \$317,419 | \$0 | \$0 | \$0 |
| Principal 5/1 | \$900,000 | \$0 | \$0 | \$0 |

2020 A2

| | | | | |
|---------------|-----------|----------|----------|-----|
| Interest 11/1 | \$99,481 | \$99,481 | \$99,481 | \$0 |
| Interest 5/1 | \$99,481 | \$0 | \$0 | \$0 |
| Principal 5/1 | \$225,000 | \$0 | \$0 | \$0 |

| | | | | |
|---------------------------|--------------------|------------------|------------------|------------|
| Total Expenditures | \$1,958,800 | \$416,900 | \$416,900 | \$0 |
|---------------------------|--------------------|------------------|------------------|------------|

| | | | | |
|---------------------------------|------------------|--|--------------------|--|
| Fund Balance - Beginning | \$433,443 | | \$1,051,969 | |
|---------------------------------|------------------|--|--------------------|--|

| | | | | |
|------------------------------|------------------|--|--------------------|--|
| Fund Balance - Ending | \$423,081 | | \$2,604,238 | |
|------------------------------|------------------|--|--------------------|--|

| | |
|-----------------------|--------------------|
| Reserve A1 | \$378,625 |
| Reserve A2 | \$218,250 |
| Interest A1 | \$6,774 |
| Interest A2 | \$3,904 |
| Revenue | \$1,931,405 |
| Prepayment A1 | \$4,445 |
| Prepayment A2 | \$2,679 |
| General Redemption | \$34,188 |
| Assessment Receivable | \$23,967 |
| | \$2,604,238 |

Aberdeen
Community Development District
Debt Service Fund-Series 2018
Statement of Revenues & Expenditures
For the Period Ending
April 30, 2023

| | APPROVED BUDGET | PRORATED Thru 04/30/23 | ACTUAL Thru 04/30/23 | VARIANCE |
|--|--------------------|---------------------------|-------------------------|----------|
|--|--------------------|---------------------------|-------------------------|----------|

Revenues:

| | | | | |
|--------------------------------|------------------|------------------|------------------|----------------|
| Special Assessments - Tax Roll | \$134,960 | \$134,960 | \$134,341 | (\$619) |
| Interest Income | \$200 | \$200 | \$2,714 | \$2,514 |
| Total Revenues | \$135,160 | \$135,160 | \$137,055 | \$1,895 |

Expenditures

| | | | | |
|---------------------------|------------------|-----------------|-----------------|------------|
| Interest 11/1 | \$48,100 | \$48,100 | \$48,100 | \$0 |
| Interest 5/1 | \$48,410 | \$0 | \$0 | \$0 |
| Principal 5/1 | \$35,000 | \$0 | \$0 | \$0 |
| Total Expenditures | \$179,610 | \$48,100 | \$48,100 | \$0 |

| | | | | |
|---------------------------------------|-------------------|-----------------|-----------------|----------------|
| Excess Revenues (Expenditures) | (\$44,450) | \$87,060 | \$88,955 | \$1,895 |
|---------------------------------------|-------------------|-----------------|-----------------|----------------|

| | | | | |
|-----------------------------------|-------------------|--|-----------------|--|
| NET CHANGE IN FUND BALANCE | (\$44,450) | | \$88,955 | |
|-----------------------------------|-------------------|--|-----------------|--|

| | | | | |
|---------------------------------|-----------------|--|------------------|--|
| Fund Balance - Beginning | \$49,605 | | \$118,454 | |
|---------------------------------|-----------------|--|------------------|--|

| | | | | |
|------------------------------|----------------|--|------------------|--|
| Fund Balance - Ending | \$5,155 | | \$207,409 | |
|------------------------------|----------------|--|------------------|--|

| | | |
|--|-----------------------|-----------|
| | Reserve | \$67,138 |
| | Revenue | \$136,944 |
| | Prepayment | \$128 |
| | Redemption | \$1,538 |
| | Assessment Receivable | \$1,661 |
| | | \$207,409 |

Aberdeen

Community Development District

Capital Reserve Fund

Statement of Revenues & Expenditures

For the Period Ending

April 30, 2023

| | ADOPTED BUDGET | PRORATED Thru 04/30/23 | ACTUAL Thru 04/30/23 | VARIANCE |
|---------------------------------------|--------------------|---------------------------|-------------------------|-----------------|
| <u>Revenues:</u> | | | | |
| Insurance Proceeds | \$0 | \$0 | \$785 | \$785 |
| Impact Fees | \$0 | \$0 | \$10,153 | \$10,153 |
| Interest | \$3,000 | \$3,000 | \$15,322 | \$12,322 |
| Total Revenues | \$3,000 | \$3,000 | \$26,259 | \$23,259 |
| <u>Expenditures</u> | | | | |
| Capital Outlay | \$150,000 | \$87,500 | \$25,490 | \$62,010 |
| Repair and Replacements | \$100,000 | \$58,333 | \$52,235 | \$6,099 |
| Total Expenditures | \$250,000 | \$145,833 | \$77,725 | \$68,109 |
| Excess Revenues (Expenditures) | (\$247,000) | | (\$51,466) | |
| Fund Balance - Beginning | \$778,569 | | \$767,948 | |
| Fund Balance - Ending | \$531,569 | | \$716,483 | |

Aberdeen
Community Development District
Capital Projects Fund
Statement of Revenues & Expenditures
For the Period Ending
April 30, 2023

| | SERIES 2018 |
|---------------------------------------|-----------------|
| <u>REVENUES:</u> | |
| Interest | \$928 |
| Total Revenues | \$928 |
| <u>EXPENDITURES:</u> | |
| Capital Outlay | \$0 |
| Cost of Issuance | \$0 |
| Total Expenditures | \$0 |
| <u>OTHER SOURCES/(USES)</u> | |
| Interfund Transfer In/(Out) | \$0 |
| Total Other Sources/(Uses) | \$0 |
| Excess Revenues (Expenditures) | \$928 |
| Fund Balance - Beginning | \$47,501 |
| Fund Balance - Ending | \$48,429 |

Aberdeen
Community Development District
Long Term Debt Report

| Series 2018 Special Assessment Bonds | |
|---|--------------------|
| Interest Rate: | 4%-5.1% |
| Maturity Date: | 5/1/2049 |
| Reserve Fund Definition: | 50% of MADS |
| Reserve Fund Requirement: | \$67,138 |
| Reserve Fund Balance: | \$67,138 |
| | |
| Bonds outstanding - 11/01/2018 | \$2,065,000 |
| Less: February 3, 2020 (Prepayment) | (\$5,000) |
| Less: May 1, 2020 (Mandatory) | (\$30,000) |
| Less: August 3, 2020 (Prepayment) | (\$5,000) |
| Less: November 1, 2020 (Prepayment) | (\$5,000) |
| Less: May 1, 2021 (Mandatory) | (\$35,000) |
| Less: May 1, 2021 (Prepayment) | (\$5,000) |
| Less: May 1, 2022 (Mandatory) | (\$35,000) |
| Less: May 1, 2022 (Prepayment) | (\$5,000) |
| Current Bonds Outstanding | \$1,940,000 |

| Series 2020-A1 Special Assessment Revenue Refunding Bonds | |
|--|---------------------|
| Interest Rate: | 2.625-5.0% |
| Maturity Date: | 11/1/2036 |
| Reserve Fund Definition: | 25% of DSRF |
| Reserve Fund Requirement: | \$378,625 |
| Reserve Fund Balance: | \$378,625 |
| | |
| Bonds outstanding - 5/20/2020 | \$18,485,000 |
| Less: May 1, 2021 (Mandatory) | (\$815,000) |
| Less: November 1, 2021 (Prepayment) | (\$15,000) |
| Less: May 1, 2022 (Mandatory) | (\$855,000) |
| Less: May 1, 2022 (Prepayment) | (\$10,000) |
| Current Bonds Outstanding | \$16,790,000 |

| Series 2020 A-2 Special Assessment Revenue Refunding Bonds | |
|---|--------------------|
| Interest Rate: | 4.0-4.75% |
| Maturity Date: | 5/1/2049 |
| Reserve Fund Definition: | 50% of DSRF |
| Reserve Fund Requirement: | \$218,250 |
| Reserve Fund Balance: | \$218,250 |
| | |
| Bonds outstanding - 5/20/2020 | \$4,890,000 |
| Less: May 1, 2021 (Mandatory) | (\$215,000) |
| Less: May 1, 2022 (Mandatory) | (\$225,000) |
| Less: May 1, 2022 (Prepayment) | (\$150,000) |
| Current Bonds Outstanding | \$4,300,000 |

C.

ABERDEEN COMMUNITY DEVELOPMENT DISTRICT

Fiscal Year 2023 Summary of Assessment Receipts

| ASSESSED | # UNITS ASSESSED | SERIES 2020 DEBT ASMT | SERIES 2018 DEBT ASMT | FY23 O&M ASMT | TOTAL ASSESSED |
|---------------------------------|---------------------|--------------------------|--------------------------|------------------|-------------------|
| NET ASSESSMENTS TAX ROLL | 50,936 | 1,947,437.99 | 134,960.07 | 1,138,301.72 | 3,220,699.78 |
| TAX ROLL RECEIVED | | 1,938,506.94 | 134,341.15 | 1,133,081.43 | 3,205,929.52 |
| BALANCE DUE | | 8,931.05 | 618.92 | 5,220.29 | 14,770.26 |

Units include 49,000 square feet of Commercial

| SUMMARY OF TAX ROLL RECEIPTS | | | | | |
|--------------------------------|---------------|---------------------|------------------------------|------------------------------|---------------------|
| ST JOHNS COUNTY DISTRIBUTION | DATE RECEIVED | AMOUNT RECEIVED | SERIES 2020 DEBT RECEIPTS | SERIES 2018 DEBT RECEIPTS | O&M RECEIPTS |
| 1 | 11/2/2022 | 10,254.76 | 6,200.67 | 429.72 | 3,624.37 |
| 2 | 11/17/2022 | 87,494.29 | 52,904.56 | 3,666.36 | 30,923.37 |
| 3 | 11/28/2022 | 85,441.91 | 51,663.56 | 3,580.35 | 30,198.00 |
| 4 | 12/12/2022 | 298,327.09 | 180,387.35 | 12,501.09 | 105,438.65 |
| 5 | 12/15/2022 | 440,661.38 | 266,451.63 | 18,465.46 | 155,744.29 |
| 6 | 1/20/2023 | 2,101,476.91 | 1,270,685.33 | 88,060.20 | 742,731.38 |
| INTEREST | 2/1/2023 | 4,308.30 | 2,605.07 | 180.53 | 1,522.70 |
| 7 | 2/21/2023 | 123,206.90 | 74,498.65 | 5,162.86 | 43,545.39 |
| 8 | 3/30/2023 | 12,637.83 | 7,641.63 | 529.58 | 4,466.62 |
| INTEREST | 4/6/2023 | 2,482.79 | 1,501.25 | 104.04 | 877.50 |
| 9 | 5/8/2023 | 39,637.36 | 23,967.24 | 1,660.96 | 14,009.16 |
| | | | - | - | - |
| | | | - | - | - |
| | | | - | - | - |
| | | | - | - | - |
| | | | - | - | - |
| TOTAL TAX ROLL RECEIPTS | | 3,205,929.52 | 1,938,506.94 | 134,341.15 | 1,133,081.43 |

| | | | | |
|-----------------------------------|---------------|---------------|---------------|---------------|
| PERCENT COLLECTED TAX ROLL | 99.54% | 99.54% | 99.54% | 99.54% |
|-----------------------------------|---------------|---------------|---------------|---------------|

D.

Aberdeen

Community Development District

Check Run Summary

4/1/2023-4/30/2023

| | Check Date | Check No. | | Amount |
|---|------------|-------------------------|----|---------------------|
| General Fund - Wells Fargo | | | | |
| Payroll | 4/26/23 | 50905-50909 | \$ | 923.50 |
| Total | | | | \$ 923.50 |
| General Fund - Wells Fargo | | | | |
| Accounts Payable | 4/7/23 | 4605-4610 | \$ | 26,004.34 |
| | 4/20/23 | 4611-4621 | \$ | 8,556.41 |
| | | | | \$ 34,560.75 |
| Capital Reserve Fund - Wells Fargo | | | | |
| Accounts Payable | 4/7/23 | 144 | \$ | 12,745.00 |
| | | | | \$ 12,745.00 |
| Total | | | | \$ 47,305.75 |
| Autopayments - Wells Fargo | | | | |
| | 4/3/23 | Hi-Tech System | \$ | 250.00 |
| | 4/7/23 | Comcast | \$ | 498.54 |
| | 4/11/23 | JEA Utilities | \$ | 10,913.03 |
| | 4/17/23 | Comcast | \$ | 776.90 |
| | 4/25/23 | Comcast | \$ | 191.24 |
| | 4/25/23 | Wellbeats | \$ | 249.00 |
| | 4/28/23 | Wells Fargo Credit Card | \$ | 5,957.85 |
| Total | | | | \$ 18,836.56 |

*Autopayment invoices and Wells Fargo Credit Card invoices will be available upon request.

Check Approval Form

Date: April 26, 2023

District: Aberdeen CDD

Fund Code: 1

Beginning Check #: 50905

Ending Check #: 50909

Total Amount of Checks: \$ 923.50 New Balance

Balance in Account***: \$ 693,307.42 \$ 692,383.92

Recent Deposits: _____

Prepared by: Daniel Laughlin

Signature: 

Approved by: Jim Oliver

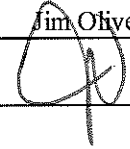
Signature: 

| CHECK # | EMP # | EMPLOYEE NAME | CHECK AMOUNT | CHECK DATE |
|---------|-------|----------------------|--------------|------------|
| 50905 | 12 | ANGELA MARIE ANDREWS | 184.70 | 4/26/2023 |
| 50906 | 17 | HARRIET S CLARKE | 184.70 | 4/26/2023 |
| 50907 | 15 | LAUREN Q EGGLESTON | 184.70 | 4/26/2023 |
| 50908 | 18 | PAUL R FOGEL | 184.70 | 4/26/2023 |
| 50909 | 16 | THOMAS G MARMO | 184.70 | 4/26/2023 |

TOTAL FOR REGISTER 923.50

ABER ABERDEEN DLAUGHLIN

ATTENDANCE SHEET

District: Aberdeen

Meeting Date: 04.25.23

| | Supervisor | In Attendance | Fees |
|----|---|-------------------------------------|-------------|
| 1. | Lauren Eggleston <i>Chairperson</i> | <input checked="" type="checkbox"/> | \$200 |
| 2. | Susie Clarke <i>Assistant Secretary</i> | <input checked="" type="checkbox"/> | \$200 |
| 3. | Thomas Marmo <i>Assistant Secretary</i> | <input checked="" type="checkbox"/> | \$200 |
| 4. | Paul Fogel <i>Vice Chairman</i> | <input checked="" type="checkbox"/> | \$200 |
| 5. | Angela Andrews <i>Assistant Secretary</i> | <input checked="" type="checkbox"/> | \$200 |

District Manager:

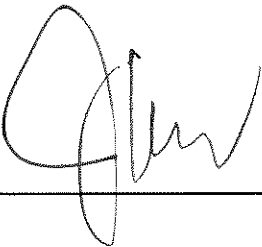
 4/25/2023

PLEASE RETURN COMPLETED FORM TO OKSANA KUZMUK

| CHECK DATE | VEND# | INVOICE DATE | INVOICE | EXPENSED TO... YRMO | DPT | ACCT# | SUB | SUBCLASS | VENDOR NAME | STATUS | AMOUNT | CHECK AMOUNT | CHECK # |
|------------|-------|--------------|----------|---------------------|-----|-------|-------|----------|----------------------------|--------|----------|--------------|---------|
| 4/07/23 | 00153 | 3/27/23 | 92172004 | 202303 | 320 | 57200 | 46000 | | FIRST AID/SAFETY SUPPLIES | * | 2,184.90 | | |
| | | | | | | | | | CINTAS FIRE 636525 | | | 2,184.90 | 004605 |
| 4/07/23 | 00279 | 3/20/23 | 1528 | 202304 | 320 | 53800 | 45913 | | APR LIFEGUARDS | * | 7,312.29 | | |
| | | | | | | | | | ELITE AMENITIES NE FL, LLC | | | 7,312.29 | 004606 |
| 4/07/23 | 00259 | 3/31/23 | 10876575 | 202303 | 320 | 53800 | 45918 | | MAR GENREERAL MANAGER | * | 3,096.10 | | |
| | | 3/31/23 | 10876575 | 202303 | 320 | 53800 | 45915 | | MAR FRONT DESK | * | 1,989.91 | | |
| | | 3/31/23 | 10876575 | 202303 | 320 | 53800 | 45505 | | MAR GROUNDS MAINTENANCE | * | 527.73 | | |
| | | 3/31/23 | 10876575 | 202303 | 320 | 53800 | 45506 | | MAR GROUNDS MAINTENANCE | * | 1,014.67 | | |
| | | 3/31/23 | 10876575 | 202303 | 320 | 53800 | 46000 | | MAR BUILD MAINT SUREVSR | * | 2,541.86 | | |
| | | 3/31/23 | 10876575 | 202303 | 320 | 53800 | 45917 | | MAR BUILDING MAINT STAFF | * | 1,637.72 | | |
| | | | | | | | | | FIRST SERVICE RESIDENTIAL | | | 10,807.99 | 004607 |
| 4/07/23 | 00213 | 3/31/23 | 77716 | 202303 | 320 | 53800 | 46100 | | MAR LAKE MAINTENANCE | * | 2,675.00 | | |
| | | | | | | | | | FUTURE HORIZONS, INC | | | 2,675.00 | 004608 |
| 4/07/23 | 00079 | 4/01/23 | 13129561 | 202304 | 320 | 53800 | 45507 | | APR POOL CHEMICALS | * | 2,717.01 | | |
| | | | | | | | | | POOLSURE | | | 2,717.01 | 004609 |
| 4/07/23 | 00060 | 3/01/23 | 61704980 | 202303 | 320 | 53800 | 45926 | | MAR PEST CONTROL | * | 109.15 | | |
| | | 3/01/23 | 61705273 | 202303 | 320 | 53800 | 45926 | | MAR FIRE ANTS | * | 99.00 | | |
| | | 4/03/23 | 61716268 | 202304 | 320 | 53800 | 45926 | | APR FIRE ANTS | * | 99.00 | | |
| | | | | | | | | | TURNER PEST CONTROL LLC | | | 307.15 | 004610 |
| 4/20/23 | 00240 | 3/15/23 | 03122023 | 202303 | 320 | 53800 | 46900 | | HVAC REPAIR | * | 189.00 | | |
| | | 3/25/23 | 04102023 | 202303 | 320 | 53800 | 46900 | | QTRLY HVAC PREVENT MAINT | * | 375.00 | | |
| | | | | | | | | | ABERDEEN AIR, LLC | | | 564.00 | 004611 |
| 4/20/23 | 00286 | 3/20/23 | 5435112 | 202303 | 310 | 51300 | 48000 | | NOTICE OF MEETING 8546071 | * | 66.64 | | |
| | | | | | | | | | CA FLORIDA HOLDINGS,LLC | | | 66.64 | 004612 |

ABER ABERDEEN OKUZMUK

| CHECK DATE | VEND# | INVOICE DATE | INVOICE | YRMO | DPT | ACCT# | SUB | SUBCLASS | VENDOR NAME | STATUS | AMOUNT | CHECK AMOUNT | CHECK # |
|------------|-------|--------------|----------|--------|-----------|-------|-----|----------|----------------------------------|--------|----------|--------------|---------|
| 4/20/23 | 00188 | 4/10/23 | 14 | 202304 | 310-51300 | 31300 | | | DISCLOSURE SERVICES LLC | * | 250.00 | 250.00 | 004613 |
| 4/20/23 | 00278 | 4/01/23 | 04012023 | 202304 | 320-53800 | 45925 | | | NATIONAL TELECOM DEPLOYMENT DBA | * | 299.40 | 299.40 | 004614 |
| 4/20/23 | 00013 | 4/07/23 | 0207668 | 202303 | 310-51300 | 31100 | | | ENGLAND THIMS & MILLER, INC. | * | 322.50 | 322.50 | 004615 |
| 4/20/23 | 00259 | 4/01/23 | 10878967 | 202304 | 310-51300 | 34000 | | | FIRST SERVICE RESIDENTIAL | * | 1,075.00 | 1,075.00 | 004616 |
| 4/20/23 | 00017 | 4/01/23 | 692 | 202304 | 310-51300 | 34000 | | | GOVERNMENTAL MANAGEMENT SERVICES | * | 4,399.67 | 5,269.72 | 004617 |
| | | 4/01/23 | 692 | 202304 | 310-51300 | 35100 | | | | * | 150.00 | | |
| | | 4/01/23 | 692 | 202304 | 310-51300 | 31300 | | | | * | 583.33 | | |
| | | 4/01/23 | 692 | 202304 | 310-51300 | 51000 | | | | * | .87 | | |
| | | 4/01/23 | 692 | 202304 | 310-51300 | 42000 | | | | * | 44.21 | | |
| | | 4/01/23 | 692 | 202304 | 310-51300 | 42500 | | | | * | 31.80 | | |
| | | 4/01/23 | 692 | 202304 | 310-51300 | 41000 | | | | * | 59.84 | | |
| 4/20/23 | 00271 | 4/18/23 | 3209046 | 202303 | 310-51300 | 31500 | | | KUTAK ROCK LLP | * | 3,111.96 | 3,111.96 | 004618 |
| | | 4/18/23 | 3209046 | 202303 | 310-51300 | 31500 | | | | V | 3,111.96 | | |
| 4/20/23 | 00304 | 4/06/23 | 3 | 202304 | 320-57200 | 49400 | | | CANDACE MINNICKS DBA | * | 450.00 | 450.00 | 004619 |
| 4/20/23 | 00060 | 4/05/23 | 61715996 | 202304 | 320-53800 | 45926 | | | TURNER PEST CONTROL LLC | * | 109.15 | 109.15 | 004620 |

| CHECK DATE | VEND# |INVOICE..... DATE INVOICE | ...EXPENSED TO... YRMO DPT ACCT# SUB SUBCLASS | VENDOR NAME | STATUS | AMOUNT |CHECK..... AMOUNT # |
|--------------------|-------|-----------------------------------|--|-----------------------------|--------|-----------|----------------------------|
| 4/20/23 | 00221 | 4/01/23 2917 | 202304 320-53800-45919 | ROBERTA G NAGLE DBA UNICORN | * | 150.00 | 150.00 004621 |
| TOTAL FOR BANK A | | | | | | 34,560.75 | |
| TOTAL FOR REGISTER | | | | | | 34,560.75 | |

Check Approval Form

General Fund

Date: April 7, 2023

District: Aberdeen CDD

Fund Code: 1

Beginning Check #: 4605

Ending Check #: 4610

| | | |
|-------------------------|--------------|--------------|
| Total Amount of Checks: | \$ 26,004.34 | New Balance |
| Balance in Account***: | \$ 97,743.04 | \$ 71,738.70 |

Recent Deposits: _____

Prepared by: Todd R. Polvere

Signature: 

Approved by: Jim Oliver

Signature: _____

BANK A: ABERDEEN CDD

| VEND NO. | Invoice Vendor | Inv. No. | ---General Ledger#----- | St Cr | DUE DATE | GROSS AMOUNT | DISC AMOUNT | NET AMOUNT | CHECK NO. |
|----------|----------------------------|------------------------------|-------------------------|-------|----------|--------------|-------------|------------|-----------|
| 00153 | 32723 92172004 | 001-320-57200-46000 | 32723 | | 32723 | 2,184.90 | .00 | 2,184.90 | 004605 |
| | FIRST AID/SAFETY SUPPLIES | REPAIRS AND REPLACEMENTS | | | | | | | |
| | CINTAS FIRE 636525 | | | | | 2,184.90 | .00 | 2,184.90 | 004605 |
| 00279 | 32023 1528 | 001-320-53800-45913 | 32023 | | 32023 | 7,312.29 | .00 | 7,312.29 | 004606 |
| | APR LIFEGUARDS | AMENITY - LIFEGUARDS | | | | | | | |
| | ELITE AMENITIES NE FL, LLC | | | | | 7,312.29 | .00 | 7,312.29 | 004606 |
| 00259 | 33123 10876575 | 001-320-53800-45918 | 33123 | | 33123 | 3,096.10 | .00 | 3,096.10 | |
| | MAR GENRRAL MANAGER | FACILITY MANAGER | | | | | | | |
| 00259 | 33123 10876575 | 001-320-53800-45915 | 33123 | | 33123 | 1,989.91 | .00 | 1,989.91 | |
| | MAR FRONT DESK | RESIDENT SERVICE COORDINATOR | | | | | | | |
| 00259 | 33123 10876575 | 001-320-53800-45505 | 33123 | | 33123 | 527.73 | .00 | 527.73 | |
| | MAR GROUNDS MAINTENANCE | AMENT-POOL MAINTENANCE | | | | | | | |
| 00259 | 33123 10876575 | 001-320-53800-45506 | 33123 | | 33123 | 1,014.67 | .00 | 1,014.67 | |
| | MAR GROUNDS MAINTENANCE | AMENT- JANITORIAL MAINT | | | | | | | |
| 00259 | 33123 10876575 | 001-320-53800-46000 | 33123 | | 33123 | 2,541.86 | .00 | 2,541.86 | |
| | MAR BUILD MAINT SUREVSR | OPERATIONS MANAGEMENT | | | | | | | |
| 00259 | 33123 10876575 | 001-320-53800-45917 | 33123 | | 33123 | 1,637.72 | .00 | 1,637.72 | |
| | MAR BUILDING MAINT STAFF | GENERAL FACILITY MAINTENANCE | | | | | | | |
| | FIRST SERVICE RESIDENTIAL | | | | | 10,807.99 | .00 | 10,807.99 | 004607 |
| 00213 | 33123 77716 | 001-320-53800-46100 | 33123 | | 33123 | 2,675.00 | .00 | 2,675.00 | |
| | MAR LAKE MAINTENANCE | LAKE MAINTENANCE | | | | | | | |
| | FUTURE HORIZONS, INC | | | | | 2,675.00 | .00 | 2,675.00 | 004608 |
| 00079 | 40123 13129561 | 001-320-53800-45507 | 40123 | | 40123 | 2,717.01 | .00 | 2,717.01 | |
| | APR POOL CHEMICALS | AMENITY - POOL CHEMICALS | | | | | | | |
| | POOLSURE | | | | | 2,717.01 | .00 | 2,717.01 | 004609 |
| 00060 | 30123 61704980 | 001-320-53800-45926 | 30123 | | 30123 | 109.15 | .00 | 109.15 | |
| | MAR PEST CONTROL | PEST CONTROL | | | | | | | |
| 00060 | 30123 61705273 | 001-320-53800-45926 | 30123 | | 30123 | 99.00 | .00 | 99.00 | |
| | MAR FIRE ANTS | PEST CONTROL | | | | | | | |
| 00060 | 40323 61716268 | 001-320-53800-45926 | 40323 | | 40323 | 99.00 | .00 | 99.00 | |
| | APR FIRE ANTS | PEST CONTROL | | | | | | | |
| | TURNER PEST CONTROL LLC | | | | | 307.15 | .00 | 307.15 | 004610 |
| | ABERDEEN CDD | | | | | 26,004.34 | .00 | 26,004.34 | |
| | ABERDEEN - GENERAL FUND | | | | | 26,004.34 | .00 | 26,004.34 | |

ABER ABERDEEN TFPOLVERE



CINTAS
P.O. Box 631025
CINCINNATI, OH 45263-1025

Service / Billing # (904)562-7000
Fax # (904)562-7020
Payment Inquiry # (972)996-7923

Invoice

Ship To ABERDEEN COMMUNITY
DEVELOPMENT DISTRICT
110 FLOWER OF SCOTLAND AVE
ST JOHNS, FL 32259-6937

Invoice # 9217200429
Invoice Date 03/27/2023
Credit Terms NET 30 DAYS
Customer # 21733123
Cintas Route LOC #0292 ROUTE 0055
Order # 0060349056
Payer # 21733123

Bill To ABERDEEN COMMUNITY
DEVELOPMENT DISTRICT
110 FLOWER OF SCOTLAND AVE
ST JOHNS, FL 32259-6937

| Material # | Description | Quantity | Unit Price | Ext Price | Tax |
|--------------------------|-----------------------------------|----------|------------|------------------|-----|
| 19190 | CINTAS DELUXE AED CABINET W/ALARM | 1 EA | \$203.02 | \$203.02 | |
| 99948 | AED PRESCRIPTION 1 YR | 1 EA | \$65.00 | \$65.00 | |
| 341810 | SGN AED VISI 6X9 ACRYLIC | 1 EA | \$19.88 | \$19.88 | |
| 4003Z | ZOLL 3 AED-AUTOMATIC | 1 EA | \$1897.00 | \$1897.00 | |
| Invoice Sub-total | | | | \$2184.90 | |
| Tax | | | | \$0.00 | |
| Invoice Total | | | | \$2184.90 | |

Remit To CINTAS
P.O. Box 631025
CINCINNATI, OH 45263-1025

Note



*First Aid Facility
Supplies
vs
4/4/23*

1,320.572.460

Elite Amenities NE FL, LLC

4116 Running Bear Lane
Saint Johns, FL 32259 US
904-710-0172
eric@eliteamenities.com

INVOICE

BILL TO
Kate Trivelpiece
Aberdeen Amenity Center
110 Flower of Scotland Ave.
St. Johns, FL 32259

INVOICE 1528
DATE 03/20/2023
TERMS Due in 10 days
DUE DATE 04/01/2023

| DATE | DESCRIPTION | QTY | RATE | AMOUNT |
|------|--------------------|-----|----------|----------|
| | Lifeguards - April | 1 | 7,312.29 | 7,312.29 |

BALANCE DUE **\$7,312.29**

320.538.45913
Lifeguard Contract
KS
3/21/23

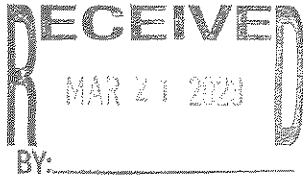

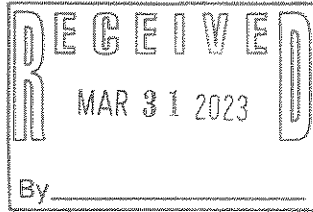
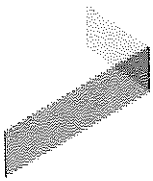

INVOICE

FirstService

RESIDENTIAL

Aberdeen Community Development District
110 Flower of Scotland Avenue
Saint Johns, FL 32259
Anh.Nguyen@fsresidential.com

Invoice Number 10876575
Invoice Date 3/31/2023
Terms 15 ePay ACH BP
Period Start 3/11/2023
Period End 3/24/2023

Customer 100-OSNC
Account # PAY-OSNC
Total Amount Due: \$10,807.99

| Position | Labor Rate | Employee | Hours | Pay Rate | Amount | |
|---|------------|------------------------|----------------|----------|--------------|--------------------|
| General Manager, Property Oper | 15.00% | Trivelpiece, Katherine | 40.00 REGULAR | \$33.65 | \$1,548.05 | |
| ✓ General Manager, Property Oper 1.320.538.45918 | 15.00% | Trivelpiece, Katherine | 40.00 VACATION | \$33.65 | \$1,548.05 | |
| | | | | | Subtotal | \$3,096.10 |
| Staff, Front Desk | 25.00% | Arnold, Demetric E | 12.00 PTO | \$17.00 | \$255.00 | |
| Staff, Front Desk | 25.00% | Arnold, Demetric E | 68.16 REGULAR | \$17.00 | \$1,448.41 | |
| ✓ Staff, Front Desk 1.320.538.45915 | 25.00% | Mccarthy, Moira | 15.28 REGULAR | \$15.00 | \$286.50 | |
| | | | | | Subtotal | \$1,989.91 |
| Staff, Grounds Maint | 25.00% | Abshire, Caleb L | 77.12 REGULAR | \$16.00 | \$1,542.40 | |
| 1.320.538.45505 → \$527.73 | | | | | | |
| 1.320.538.45506 → \$1,014.67 | | | | | | |
| | | | | | Subtotal | \$1,542.40 |
| ✓ Supervisor, Building Maint 1.320.538.460 | 25.00% | Parker, Jay | 78.21 REGULAR | \$26.00 | \$2,541.86 | |
| | | | | | Subtotal | \$2,541.86 |
| Staff, Building Maint | 25.00% | Henry, Brandon E | 16.00 PTO | \$18.50 | \$370.00 | |
| ✓ Staff, Building Maint 1.320.538.45917 | 25.00% | Henry, Brandon E | 54.82 REGULAR | \$18.50 | \$1,267.72 | |
| | | | | | Subtotal | \$1,637.72 |
| | | | | | Subtotal | \$10,807.99 |
| | | | | | Tax | \$0.00 |
| | | | | | Total | \$10,807.99 |

INVOICE

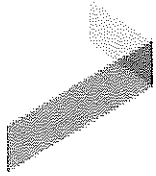

FirstService

RESIDENTIAL

Aberdeen Community Development District
110 Flower of Scotland Avenue
Saint Johns, FL 32259
Anh.Nguyen@fsresidential.com

Invoice Number 10876575
Invoice Date 3/31/2023
Terms 15 ePay ACH BP
Period Start 3/11/2023
Period End 3/24/2023

Customer 100-0SNC
Account # PAY-0SNC
Total Amount Due: \$10,807.99

| Position | Labor Rate | Employee | Hours | Pay Rate | Amount |
|--------------------------------|------------|----------|-------|----------|------------|
| General Manager, Property Oper | | | | | \$3,096.10 |
| Staff, Building Maint | | | | | \$1,637.72 |
| Staff, Front Desk | | | | | \$1,989.91 |
| Staff, Grounds Maint | | | | | \$1,542.40 |
| Supervisor, Building Maint | | | | | \$2,541.86 |

Future Horizons, Inc

403 N First Street
 PO Box 1115
 Hastings, FL 32145
 USA

Voice: 904-692-1187
 Fax: 904-692-1193

INVOICE

Invoice Number: 77716
 Invoice Date: Mar 31, 2023
 Page: 1

| |
|---|
| Bill To: |
| Aberdeen CDD 475 West Town Place Suite 114 St. Augustine, FL 32092 |

| |
|---|
| Ship to: |
| Aberdeen CDD 475 West Town Place Suite 114 St. Augustine, FL 32092 |

| | | | |
|---------------------|------------------------|----------------------|-----------------|
| Customer ID | Customer PO | Payment Terms | |
| Aberdeen01 | Per Contract | Net 30 Days | |
| Sales Rep ID | Shipping Method | Ship Date | Due Date |
| | Hand Deliver | | 4/30/23 |

| Quantity | Item | Description | Unit Price | Amount |
|----------|----------------------|--|------------|----------|
| 1.00 | Aquatic Weed Control | Aquatic Weed Control services performed in March 2023 1,320,538.461 | 2,675.00 | 2,675.00 |

RECEIVED
 APR 13 2023
 BY: _____

| | |
|------------------------|-----------------|
| Subtotal | 2,675.00 |
| Sales Tax | |
| Freight | |
| Total Invoice Amount | 2,675.00 |
| Payment/Credit Applied | |
| TOTAL | 2,675.00 |

Check/Credit Memo No:

Overdue invoices are subject to finance charges.



1707 Townhurst Dr.
Houston TX 77043
(800) 858-POOL (7665)
www.poolsure.com

Invoice

Date 4/1/2023

Invoice # 131295613546

| | |
|----------|-----------|
| Terms | Net 20 |
| Due Date | 4/21/2023 |
| PO # | |

| | |
|---|--|
| Bill To GMS LLC Aberdeen CDD 475 West Town Place Suite 114 St. Augustine FL 32092 | Ship To Aberdeen CCD 110 Flowers of Scotland Jacksonville FL 32259 |
|---|--|

| Item ID | Description | Qty | Units | Amount |
|----------------|-------------------------------------|-----|-------|----------|
| WM-CHEM-FLAT | Water Management Flat Billing Rate | 1 | ea | 2,646.54 |
| WM-SHED RENTAL | Monthly rental fee for storage shed | 1 | ea | 10.00 |
| Fuel Surcharge | Fuel/Environmental Transit Fee | 1 | ea | 60.47 |

1,320.538.45507

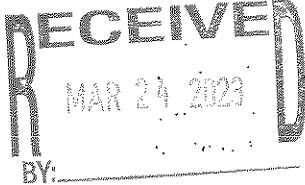
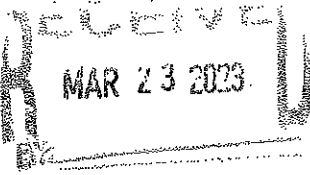
Subtotal 2,717.01
 Shipping Cost (FEDEX GROUND) 0.00
 Total 2,717.01
 Amount Due \$2,717.01

Remittance Slip

Customer
13ABE100
Invoice #
131295613546

Amount Due \$2,717.01

Amount Paid _____

Make Checks Payable To
Poolsure
PO Box 55372
Houston, TX 77255-5372



131295613546

Service Slip/Invoice



PAYMENT ADDRESS:
 Turner Pest Control LLC • P.O. Box 952503 • Atlanta, Georgia 31192-2503
 904-355-5300 • Fax: 904-353-1499 • Toll Free: 800-225-5305 • turnerpest.com

Turner Pest Control LLC
 P.O. Box 952503
 Atlanta, GA 31192-2503
 904-355-5300

INVOICE: 617049807
DATE: 3/1/2023
ORDER: 617049807

BILL TO: [139845]
 Aberdeen
 Aberdeen - CDD
 C/O Government Services
 475 W. Town Place - Suite 114
 Saint Augustine, FL 32092

Work Location: [139845] 904-626-0375
 Aberdeen
 Aberdeen - CDD
 110 Flower Of Scotland Ave
 Saint Johns, FL 32259-6937

1,320.538.45926

| Work Date | Time | Target Pest | Technician | Time In |
|----------------|----------|--------------|------------|----------|
| 3/1/2023 | 01:44 PM | | | 01:44 PM |
| Purchase Order | Terms | Last Service | Map Code | Time Out |
| | NET 30 | 3/1/2023 | 121:05 | 02:07 PM |

| Service | Description | Price |
|---------|---|----------------------------|
| CPCM | Commercial Pest Control - Monthly Service | \$109.15 |
| | | SUBTOTAL \$109.15 |
| | | TAX \$0.00 |
| | | AMT. PAID \$0.00 |
| | | TOTAL \$109.15 |
| | | AMOUNT DUE \$109.15 |

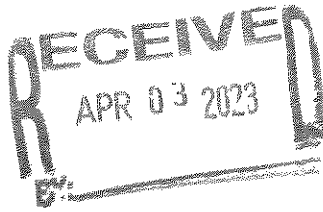

TECHNICIAN SIGNATURE

CUSTOMER SIGNATURE

Balances outstanding over 30 days from the date of service may be subject to a late fee of the lesser of 1.5% per month (18% per year) or the maximum allowed by law. Customer agrees to pay accrued expenses in the event of collection.

I hereby acknowledge the satisfactory completion of all services rendered, and agree to pay the cost of services as specified above.

Service Slip/Invoice



Turner Pest Control LLC
 P.O. Box 952503
 Atlanta, GA 31192-2503
 904-355-5300

INVOICE: 617052739
DATE: 3/1/2023
ORDER: 617052739

PAYMENT ADDRESS:
 Turner Pest Control LLC • P.O. Box 952503 • Atlanta, Georgia 31192-2503
 904-355-5300 • Fax: 904-353-1499 • Toll Free: 800-225-5305 • turnerpest.com

Bill To: [139845]
 Aberdeen
 Aberdeen - CDD
 C/O Government Services
 475 W. Town Place - Suite 114
 Saint Augustine, FL 32092

Work Location: [428304] 904-217-0925
 Aberdeen CDD II (Amenity Center)
 96 Bush Pl
 Fruit Cove, FL 32259-7101

1,320.538.45926

| Work Date | Time | Target Pest | Technician | Time In |
|----------------|----------|---------------------|------------|----------|
| 3/1/2023 | 12:49 PM | ANTS, FIRE ANT, ROA | | 12:49 PM |
| Purchase Order | Terms | Last Service | Map Code | Time Out |
| | NET 30 | 3/1/2023 | | 01:46 PM |

| Service | Description | Price |
|---------|---|---------------------------|
| CPCM | Commercial Pest Control - Monthly Service | \$99.00 |
| | | SUBTOTAL \$99.00 |
| | | TAX \$0.00 |
| | | AMT. PAID \$0.00 |
| | | TOTAL \$99.00 |
| | | AMOUNT DUE \$99.00 |

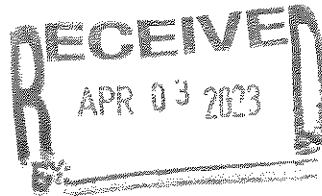

TECHNICIAN SIGNATURE

CUSTOMER SIGNATURE

Balances outstanding over 30 days from the date of service may be subject to a late fee of the lesser of 1.5% per month (18% per year) or the maximum allowed by law. Customer agrees to pay accented expenses in the event of collection.

They by acknowledge the satisfactory completion of all services rendered and agree to pay the cost of services as specified above.

Service Slip/Invoice



PAYMENT ADDRESS:
 Turner Pest Control LLC • P.O. Box 952503 • Atlanta, Georgia 31192-2503
 904-356-5300 • Fax: 904-363-1499 • Toll Free: 800-225-5305 • turnerpest.com

Turner Pest Control LLC
 P.O. Box 952503
 Atlanta, GA 31192-2503
 904-356-5300

INVOICE: 617162684
DATE: 4/3/2023
ORDER: 617162684

Bill To: [139845]
 Aberdeen
 Aberdeen - CDD
 C/O Government Services
 475 W. Town Place - Suite 114
 Saint Augustine, FL 32092

Work Location: [428304] 904-217-0925
 Aberdeen CDD II (Amenity Center)
 96 Bush Pl
 Fruit Cove, FL 32259-7101

1,320.538.45926

| Work Date | Time | Target Pest | Technician | Time In |
|----------------|----------|---------------------|------------|----------|
| 4/3/2023 | 01:47 PM | ANTS, FIRE ANT, ROA | | 01:47 PM |
| Purchase Order | Terms | Last Service | Map Code | Time Out |
| | NET 30 | 4/3/2023 | | 02:47 PM |

| Service | Description | Price |
|---------|---|---------------------------|
| CPCM | Commercial Pest Control - Monthly Service | \$99.00 |
| | | SUBTOTAL \$99.00 |
| | | TAX \$0.00 |
| | | AMT. PAID \$0.00 |
| | | TOTAL \$99.00 |
| | | AMOUNT DUE \$99.00 |

RECEIVED
 APR 14 2023
 BY: _____

TECHNICIAN SIGNATURE

CUSTOMER SIGNATURE

Balances outstanding over 30 days from the date of service may be subject to a late fee of the lesser of 1.5% per month (18% per year) or the maximum allowed by law. Customer agrees to pay accrued expenses in the event of collection.

I hereby acknowledge the satisfactory completion of all services rendered, and agree to pay the cost of services as specified above.

PLEASE PAY FROM THIS INVOICE

4-PIC 10081030-02 545714 001 4-Service Slip/Invoice - 10081030-02

Check Approval Form

General Fund

Date: April 20, 2023

District: Aberdeen CDD

Fund Code: 1

Beginning Check #: 4611

Ending Check #: 4621

Total Amount of Checks: \$ 11,668.37

Balance in Account***: \$ 701,863.83

Recent Deposits: _____

Prepared by: Todd R. Polvere

Signature: 

Approved by: Jim Oliver

Signature: 

Check #4618
VOID
4/21/23
TP

New Balance
\$ 690,195.46

ACCOUNTS PAYABLES CHECK REGISTER AS OF 4/30/2023
 001 ABERDEEN - GENERAL FUND

BANK A: ABERDEEN CDD

| VEND NO. | Invoice Date | Inv. No. | General Ledger# | St | Cr | DUE DATE | GROSS AMOUNT | DISC AMOUNT | NET AMOUNT | CHECK NO. |
|----------|--------------|----------|----------------------------------|----|----|----------|--------------|-------------|------------|-----------|
| 00240 | 31523 | 03122023 | 001-320-53800-46900 | | | 31523 | 189.00 | .00 | 189.00 | |
| | | | HVAC REPAIR | | | | | | | |
| | | | COMMON AREA MAINT | | | | | | | |
| 00240 | 32523 | 04102023 | 001-320-53800-46900 | | | 32523 | 375.00 | .00 | 375.00 | |
| | | | HVAC PREVENT MAINT | | | | | | | |
| | | | COMMON AREA MAINT | | | | | | | |
| | | | ABERDEEN AIR, LLC | | | | | | | 004611 |
| 00286 | 32023 | 5435112 | 001-310-51300-48000 | | | 32023 | 66.64 | .00 | 66.64 | |
| | | | NOTICE OF MEETING 8546071 | | | | | | | |
| | | | LEGAL ADVERTISING | | | | | | | |
| | | | CA FLORIDA HOLDINGS, LLC | | | | | | | 004612 |
| 00188 | 41023 | 14 | 001-310-51300-31300 | | | 41023 | 250.00 | .00 | 250.00 | |
| | | | SE202A-2 AMORT SCHED | | | | | | | |
| | | | DISCLOSURE SERVICES LLC | | | | | | | 004613 |
| 00278 | 40123 | 04012023 | 001-320-53800-45925 | | | 40123 | 299.40 | .00 | 299.40 | |
| | | | GYM MUSIC ANNUAL RENEWAL | | | | | | | |
| | | | SUBSCRIPTIONS | | | | | | | |
| | | | NATIONAL TELECOM DEPLOYMENT DBA | | | | | | | 004614 |
| 00013 | 40723 | 0207668 | 001-310-51300-31100 | | | 40723 | 322.50 | .00 | 322.50 | |
| | | | MAR ENGINEER SVCS | | | | | | | |
| | | | ENGLAND THIMS & MILLER, INC. | | | | | | | 004615 |
| 00259 | 40123 | 10878967 | 001-310-51300-34000 | | | 40123 | 1,075.00 | .00 | 1,075.00 | |
| | | | APR MANAGEMENT FEE | | | | | | | |
| | | | MANAGEMENT FEES | | | | | | | |
| | | | FIRST SERVICE RESIDENTIAL | | | | | | | 004616 |
| 00017 | 40123 | 692 | 001-310-51300-34000 | | | 40123 | 4,399.67 | .00 | 4,399.67 | |
| | | | APR MANAGEMENT FEES | | | | | | | |
| 00017 | 40123 | 692 | 001-310-51300-35100 | | | 40123 | 150.00 | .00 | 150.00 | |
| | | | APR INFO TECH | | | | | | | |
| | | | COMPUTER SERVICE | | | | | | | |
| 00017 | 40123 | 692 | 001-310-51300-31300 | | | 40123 | 583.33 | .00 | 583.33 | |
| | | | APR DISSEM AGENT SVCS | | | | | | | |
| | | | DISSEMINATION AGENT | | | | | | | |
| 00017 | 40123 | 692 | 001-310-51300-51000 | | | 40123 | .87 | .00 | .87 | |
| | | | OFFICE SUPPLIES | | | | | | | |
| 00017 | 40123 | 692 | 001-310-51300-42000 | | | 40123 | 44.21 | .00 | 44.21 | |
| | | | POSTAGE | | | | | | | |
| 00017 | 40123 | 692 | 001-310-51300-42500 | | | 40123 | 31.80 | .00 | 31.80 | |
| | | | COPIES | | | | | | | |
| 00017 | 40123 | 692 | 001-310-51300-41000 | | | 40123 | 59.84 | .00 | 59.84 | |
| | | | TELEPHONE | | | | | | | |
| | | | GOVERNMENTAL MANAGEMENT SERVICES | | | | | | | 004617 |
| 00271 | 41823 | 3209046 | 001-310-51300-31500 | | | 41823 | 3,111.96 | .00 | 3,111.96 | |
| | | | MAR GENERAL COUNSEL | | | | | | | |
| | | | KUYAK ROCK LLP | | | | | | | 004618 |

ABER ABERDEEN TPOLVERE

CHECK DATE 4/20/2023

14.45.14

BANK A: ABERDEEN CDD

| VEND NO. | Invoice Vendor | Inv. No. | General Ledger# | St Cr | DUE DATE | GROSS AMOUNT | DISC AMOUNT | NET AMOUNT | PO# | CHECK NO. |
|--------------|--|----------|---------------------|-------|----------|--------------|-------------|------------|-----|-----------|
| 00304 | DJ AB SPRING FESTIVAL CANDACE MINNICKS DBA | 40623 3 | 001-320-57200-49400 | | 40623 | 450.00 | .00 | 450.00 | | |
| 00060 | APR PEST CONTROL TURNER PEST CONTROL LLC | 40523 | 001-320-53800-45926 | | 40523 | 109.15 | .00 | 109.15 | | 004620 |
| 00221 | APR MAINT AND NEWS LETTER ROBERTA G NAGLE DBA UNICORN | 40123 | 001-320-53800-45919 | | 40123 | 150.00 | .00 | 150.00 | | 004621 |
| | | | | | | 11,668.37 | .00 | 11,668.37 | | |
| ABERDEEN CDD | | | | | | 11,668.37 | .00 | 11,668.37 | | |

ABERDEEN - GENERAL FUND

11,668.37

11,668.37

ABER ABERDEEN TPOLIVERE

HVAC MAINTENANCE INVOICE

Aberdeen Air, LLC
258 Grampian Highlands Drive
Saint Johns, FL 32259
(904) 342-5349
CAC1821470

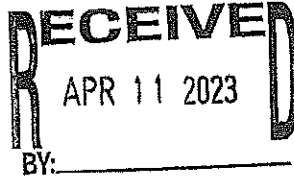

R.M.
320.538.46900
ks

March 15, 2023

Aberdeen CDD
c/o Kate Trivelpiece
110 Flower of Scotland Avenue
Saint Johns, FL 32259
(904) 217.0925 / kate.trivelpiece@fsresidential.com

Date of service: Sunday, March 12, 2023

Services: Emergency Service Call
Placed jumper wire to bypass faulty fire alarm system, which had shut down HVAC system

Amount due: \$189.00
Remit to: Aberdeen Air
258 Grampian Highlands Drive Saint Johns, FL 32259

Thank you for your support of our small business.
Should you have any questions I can be reached on (904) 342-5349.

Chrystal Blythe
Owner
Aberdeen Air, LLC
cell: (631) 383-3864 office: (904) 342-5349
service@aberdeeenac.com

SERVICE ■ INSTALLATION ■ CONTROLS



For All Your Cooling and Heating Needs
www.aberdeeenac.com ■ (904) 342-5349

QUARTERLY HVAC PREVENTATIVE MAINTENANCE

March 25, 2023

AMOUNT DUE: \$375

Aberdeen CDD
 c/o Kate Trivelpiece
 110 Flower of Scotland Avenue
 Saint Johns, FL 32259
 (904) 217.0925 / kate.trivelpiece@fsresidential.com

Date of Q1 2023 service: January 23, 2023
 Date of Q2 2023 service: April 10, 2023
 Date of Q3 2023 service: TBD July 2023
 Date of Q4 2023 service: TBD October 2023

R.M.
 320.538.46900
 (K)

Maintenance plan includes:

- Blow out and clean drain lines
- Examine outdoor unit
- Clean air handler and examine evaporator coil
- Treat indoor unit with bacterial, fungal stat, deodorizer
- Check refrigerant pressure
- Check voltage and amps on motors
- Check all electrical connections, tighten if needed
- Replace filter (customer supplied) or clean washable filter
- *additional filter charge if we supply*

RECEIVED
 APR 11 2023
 BY: _____

UNIT 1 (OLD GYM)

| UNIT 1 (OLD GYM) | | | UNIT 2 (CLUBHOUSE) | | |
|------------------|--------|-----------------------------|--------------------|--------|-----------------------------|
| AIR HANDLER | MAKE | Daikin | AIR HANDLER | MAKE | Daikin |
| | MODEL | DAR0904AB | | MODEL | DAR0904AB |
| | SERIAL | 1706492805 | | SERIAL | 1701364922 |
| CONDENSOR | MAKE | Daikin | CONDENSOR | MAKE | Daikin |
| | MODEL | DX11SA0903AB | | MODEL | DX118A0903AB |
| | SERIAL | 1711581896 | | SERIAL | 1609162909 |
| FILTER SIZE | | (2) 16x20x2 and (2) 16x25x2 | FILTER SIZE | | (2) 16x25x2 and (2) 16x20x2 |
| BELT | | (1) A39 | BELT | | (2) A43 |

UNIT 3 (OFFICE)

| UNIT 3 (OFFICE) | | | UNIT 4 (NEW GYM) | | |
|-----------------|--------|-----------------|------------------|--------|-------------------------|
| AIR HANDLER | MAKE | Bryant | CONDENSOR | MAKE | AAON |
| | MODEL | FX4DNF019 | | MODEL | CFA013BA8DJ00K |
| | SERIAL | 0722F45538 | | SERIAL | 202010CNCK08659 |
| CONDENSOR | MAKE | Bryant | AIR HANDLER | MAKE | AAON |
| | MODEL | 215BNA018A | | MODEL | H3CRB80162C278 |
| | SERIAL | 0522E03264 | | SERIAL | 202010CJEC06278 |
| FILTER SIZE | | Washable filter | FILTER SIZE | | (2) 20x20x2 (1) 16x20x2 |
| BELT | | N/A | BELT | | |

SERVICE ■ INSTALLATION ■ CONTROLS

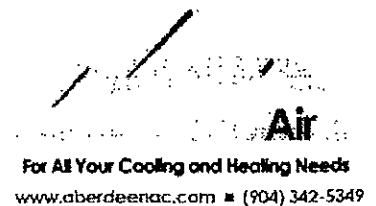

Customer Signature / Date

CAC1821470

LOCALiQ

FLORIDA

| | | | |
|--|---|--|--------------------------|
| ACCOUNT NAME Aberdeen Cdd/Gms | | ACCOUNT # 764138 | PAGE # 1 of 1 |
| INVOICE # 0005435112 | BILLING PERIOD Mar 1- Mar 31, 2023 | PAYMENT DUE DATE April 20, 2023 | |
| PREPAY (Memo Info) \$0.00 | UNAPPLIED (Included in amt due) \$0.00 | TOTAL AMOUNT DUE \$66.64 | |
| BILLING ACCOUNT NAME AND ADDRESS Aberdeen Cdd/Gms 393 Palm Coast Pkwy. S.W. Unit 4 Palm Coast, FL 32137-4774  | | BILLING INQUIRIES/ADDRESS CHANGES 1-877-736-7612 or smb@ccc.gannett.com | FEDERAL ID 47-2390983 |
| <p>Legal Entity: Gannett Media Corp. Terms and Conditions: Past due accounts are subject to interest at the rate of 18% per annum or the maximum legal rate (whichever is less). Advertiser claims for a credit related to rates incorrectly invoiced or paid must be submitted in writing to Publisher within 30 days of the invoice date or the claim will be waived. Any credit towards future advertising must be used within 30 days of issuance or the credit will be forfeited. All funds payable in US dollars.</p> | | | |

0000764138000000000000000054351120000666467179

To sign-up for E-mailed invoices and online payments please contact abgspecial@gannett.com. Previous account number: MOR 15659

| Date | Description | Amount |
|---------|---------------------|----------|
| 3/1/23 | Balance Forward | \$136.00 |
| 3/6/23 | PAYMENT - THANK YOU | -\$68.00 |
| 3/29/23 | PAYMENT - THANK YOU | -\$68.00 |

1,310,513.480

Package Advertising:

| Start-End Date | Order Number | Description | PO Number | Package Cost |
|----------------|--------------|-------------|-----------|--------------|
| 3/20/23 | 8546071 | 8546071 | | \$66.64 |

RECEIVED

APR 17 2023

BY: _____

PLEASE DETACH AND RETURN THIS PORTION WITH YOUR PAYMENT

LOCALiQ

FLORIDA

| | | |
|----------------------------------|------------------------------------|-------------|
| ACCOUNT NAME Aberdeen Cdd/Gms | PAYMENT DUE DATE April 20, 2023 | AMOUNT PAID |
| ACCOUNT NUMBER 764138 | INVOICE NUMBER 0005435112 | |

| CURRENT DUE | 30 DAYS PAST DUE | 60 DAYS PAST DUE | 90 DAYS PAST DUE | 120+ DAYS PAST DUE | UNAPPLIED PAYMENTS | TOTAL AMOUNT DUE |
|-------------|------------------|------------------|------------------|--------------------|--------------------|------------------|
| \$66.64 | \$0.00 | \$0.00 | \$0.00 | \$0.00 | \$0.00 | \$66.64 |

REMITTANCE ADDRESS (Include Account# & Invoice# on check)

CA Florida Holdings, LLC
PO Box 631244
Cincinnati, OH 45263-1244

TO PAY WITH CREDIT CARD PLEASE FILL OUT BELOW:

VISA MASTERCARD DISCOVER AMEX

Card Number _____

Exp Date ____/____/____ CVV Code _____

Signature _____ Date _____

0000764138000000000000000054351120000666467179

LOCALiQ

FLORIDA

PO Box 631244 Cincinnati, OH 45263-1244

PROOF OF PUBLICATION

Aberdeen Cdd/Gms
Aberdeen Cdd/Gms
393 Palm Coast Pkwy Sw
SUITE 4

Palm Coast FL 32137

STATE OF FLORIDA, COUNTY OF ST JOHNS

The St Augustine Record, a daily newspaper published in St Johns County, Florida; and of general circulation in St Johns County; and personal knowledge of the facts herein state and that the notice hereto annexed was Published in said newspapers in the issues dated or by publication on the newspaper's website, if authorized, on:

03/20/2023

and that the fees charged are legal.
Sworn to and subscribed before on 03/20/2023



Legal Clerk

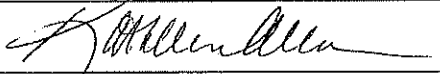

Notary, State of WI, County of Brown

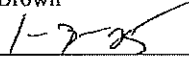

My commission expires

Publication Cost: \$66.64
Order No: 8546071 # of Copies: 1
Customer No: 764138
PO #:

THIS IS NOT AN INVOICE!

Please do not use this form for payment remittance.

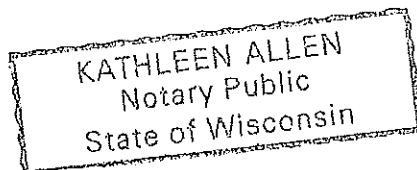

NOTICE OF MEETING ABERDEEN COMMUNITY DEVELOPMENT DISTRICT

The meeting of the Board of Supervisors (the "Board") of the Aberdeen Community Development District is scheduled to be held on Tuesday, March 28, 2023 at 6:00 p.m. located at the Aberdeen Amenity Center, 110 Flower of Scotland Avenue, Saint Johns, Florida 32259. The meeting is open to the public and will be conducted in accordance with the provisions of Florida Law for Community Development Districts. A copy of the agenda for this meeting may be obtained from the District Manager, 475 West Town Place, Suite 114, World Golf Village, St. Augustine, Florida 32092 (and phone (904) 940-5850). This meeting may be continued to a date, place and time certain, to be announced at the meeting. There may be occasions when one or more Supervisors will participate by telephone.

Any person requiring special accommodations at this meeting because of a disability or physical impairment should contact the District Manager at (904) 940-5850 at least two calendar days prior to the meeting. If you are hearing or speech impaired, please contact the Florida Relay Service at 1-800-955-8770, for aid in contacting the District Office. Each person who decides to appeal any action taken at this meeting is advised that person will need a record of proceedings and that accordingly, the person may need to ensure that a verbatim record of the proceedings is made, including the testimony and evidence upon which such appeal is to be based.

James Oliver
District Manager

Disclosure Services LLC

1005 Bradford Way
Kingston, TN 37763

Invoice

| Date | Invoice # |
|-----------|-----------|
| 4/10/2023 | 14 |

| |
|------------------------------|
| Bill To |
| Aberdeen CDD c/o GMS, LLC |

RECEIVED
APR 11 2023
BY: _____

| Terms | Due Date |
|--------|-----------|
| Net 30 | 5/10/2023 |

| Description | Amount |
|--|--------|
| Amortization Schedule Series 2020A-2 5-1-23 Prepay \$35,000 <p style="text-align: center;">1,310,513.313</p> | 250.00 |

| |
|--|
| |
|--|

| | |
|-------------------------|----------|
| Total | \$250.00 |
| Payments/Credits | \$0.00 |
| Balance Due | \$250.00 |

| |
|--------------|
| Phone # |
| 865-717-0976 |

| |
|---------------------------------|
| E-mail |
| tcarter@disclosureservices.info |

DUE: 5/4/23

INVOICE
Type: RECURRING

RECEIVED
APR 05 2023
BY: _____

| Account Number | Date | Order Number | PO Number |
|----------------|----------|--------------|-----------|
| 112534 | 4/1/2023 | 1290392 | ----- |

MAIL TO
Aberdeen CDD
Belynda Tharpe
475 W TOWN PL
Suite 114
SAINT AUGUSTINE, FL 32092
US

REMIT TO
Dynamic Media
38283 Mound Road
Sterling Heights, MI 48310
US
586-978-4214
M-F 9AM-6PM ET

| SALESPERSON |
|------------------|
| Customer Service |

| PAYMENT TERMS |
|------------------|
| Due upon receipt |

| Number | Name | Radio ID | Radio Description |
|--------|--|----------|--|
| 0001 | Aberdeen CDD Amenity Center 96 BUSH PL, SAINT JOHNS, FL 32259 | F32C7A | Sirius Customer Owned INTERNET Radio Setup SiriusXM Annual Internet Service - Primary 05/2023 - 05/2024 |

Site Reference
Fitness Center

| | Price |
|----------------|--------------|
| | \$299.40 usd |
| Site Sub Total | \$299.40 usd |
| Site Tax | \$0.00 usd |
| Site Total | \$299.40 usd |

| Account Outstanding Balances | | | |
|------------------------------|-----------|-----------|-----------|
| 0-30 | 31-60 | 61-90 | > 90 |
| \$299.40 US | \$0.00 US | \$0.00 US | \$0.00 US |

| | |
|-----------------|-------------|
| SUBTOTAL | \$299.40 US |
| SHIPPING | \$0.00 US |
| TAX | \$0.00 US |
| TOTAL | \$299.40 US |
| PAYMENTS | \$0.00 US |
| BALANCE | \$299.40 US |

*gym music
annual renewal
320.538.46500
B2 4/5/23*



Aberdeen Community Development District (CDD)
 c/o GMS, LLC
 475 West Town Place
 Suite 114
 St. Augustine, FL 32092

April 07, 2023
 Project No: 02105.27000
 Invoice No: 0207668

Project 02105.27000 Aberdeen Community Development District-2018/2019 General Consulting Engineering Services (WA#27)

Professional Services rendered through April 1, 2023

Task 01 Professional Services
 Professional Personnel

| | | | Hours | Rate | Amount | |
|--------------------|-----------|--|-------|------------------------|--------|-----------------|
| Senior Engineer | | | | | | |
| Katsaras, George | 3/4/2023 | | 1.00 | 215.00 | 215.00 | |
| Katsaras, George | 3/25/2023 | | .50 | 215.00 | 107.50 | |
| Totals | | | 1.50 | | 322.50 | |
| Total Labor | | | | | | 322.50 |
| | | | | Total this Task | | \$322.50 |

Task XP Expenses
 Total this Task 0.00

1,310.513,311

Invoice Total this Period \$322.50

RECEIVED
 APR 13 2023
 BY: _____

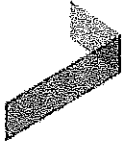

FirstService
RESIDENTIAL

Aberdeen Community Development District
110 Flower of Scotland Avenue
Saint Johns, FL 32259
Anh.Nguyen@fsresidential.com

INVOICE

Invoice Number 10878967
Invoice Date 4/1/2023
Terms 15 ePay ACH BP
Service Period 4/1/2023
Customer 100-OSNC

Invoice Type MGFEE
Account # MGF-OSNC
Total Amount Due: \$1,075.00

310.513.340

| Description | Total |
|----------------|---------------------|
| Management Fee | \$1,075.00 |
| | Subtotal \$1,075.00 |
| | Tax \$0.00 |
| | Total \$1,075.00 |

RECEIVED
APR 07 2023
BY: [Signature]
RECEIVED
APR 07 2023
BY: [Signature]

Governmental Management Services, LLC
 1001 Bradford Way
 Kingston, TN 37763

Invoice

Invoice #: 692
 Invoice Date: 4/1/23
 Due Date: 4/1/23
 Case:
 P.O. Number:

Bill To:
 Aberdeen CDD
 475 West Town Place
 Suite 114
 St. Augustine, FL 32092

| Description | Hours/Qty | Rate | Amount |
|---|---------------|----------|----------|
| Management Fees - April 2023 | 1.310.513.340 | 4,399.67 | 4,399.67 |
| Information Technology - April 2023 | 351 | 150.00 | 150.00 |
| Dissemination Agent Services - April 2023 | 313 | 583.33 | 583.33 |
| Office Supplies | 510 | 0.87 | 0.87 |
| Postage | 420 | 44.21 | 44.21 |
| Copies | 425 | 31.80 | 31.80 |
| Telephone | 410 | 59.84 | 59.84 |

RECEIVED
 APR 05 2023
 BY: _____

| | |
|-------------------------|-------------------|
| Total | \$5,269.72 |
| Payments/Credits | \$0.00 |
| Balance Due | \$5,269.72 |

KUTAK ROCK LLP

TALLAHASSEE, FLORIDA

Telephone 404-222-4600

Facsimile 404-222-4654

Federal ID 47-0597598

April 18, 2023

Check Remit To:

Kutak Rock LLP

PO Box 30057

Omaha, NE 68103-1157

ACH/Wire Transfer Remit To:

ABA #104000016

First National Bank of Omaha

Kutak Rock LLP

A/C # 24690470

Reference: Invoice No. 3209046

Client Matter No. 2223-1

Notification Email: eftgroup@kutakrock.com

Ms. Debby Bayne-Wallace
Belmont II CDD
Rizzetta & Company, Inc.
Suite 115
12750 Citrus Park Lane
Tampa, FL 33625

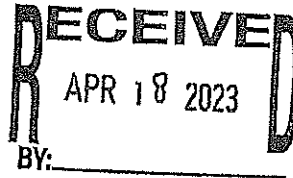

1,310,513.315

Invoice No. 3209046

2223-1

Re: General Counsel

For Professional Legal Services Rendered

| | | | | |
|----------|-----------|------|--------|---|
| 03/01/23 | J. Gillis | 0.40 | 68.00 | Confer with staff and prepare revisions to license agreement for gate installation and maintenance with Belmont Townhomes Association |
| 03/02/23 | J. Gillis | 0.30 | 51.00 | Coordinate response to auditor letter |
| 03/02/23 | L. Whelan | 0.10 | 29.00 | Review revised HOA gate installation agreement |
| 03/03/23 | L. Whelan | 0.10 | 29.00 | Confer with Ms. Wallace regarding revised scope for gate installation matter |
| 03/04/23 | W. Haber | 0.50 | 192.50 | Monitor 2023 legislative session for legislation pertaining to or affecting District |
| 03/07/23 | L. Whelan | 0.10 | 29.00 | Review draft meeting agenda for March board meeting |
| 03/10/23 | L. Whelan | 1.30 | 377.00 | Review tentative agenda for joint board meeting; review draft |

KUTAK ROCK LLP

Belmont II CDD

April 18, 2023

Client Matter No. 2223-1

Invoice No. 3209046

Page 2

| | | | | |
|-------------|-----------|-------|--------|---|
| | | | | interlocal invoice for FY 22 and confer with Ms. Wallace regarding same |
| 03/13/23 | L. Whelan | 0.10 | 29.00 | Confer with staff regarding agenda package for joint board meeting |
| 03/15/23 | L. Whelan | 0.40 | 116.00 | Prepare for March board meeting |
| 03/16/23 | L. Whelan | 0.10 | 29.00 | Confer with Ms. Evans regarding status of amenity payment to Belmont CDD |
| 03/20/23 | L. Whelan | 1.70 | 493.00 | Review February financial statements; travel to joint and regular March board meeting |
| 03/21/23 | L. Whelan | 3.30 | 957.00 | Attend regular March and joint board meetings; return travel |
| 03/22/23 | J. Gillis | 0.60 | 102.00 | Follow up from Board meeting; prepare amendment to Sitex agreement for midge fly treatment services |
| 03/22/23 | L. Whelan | 0.60 | 174.00 | Follow-up from March regular and joint board meeting; review draft amendment to midge fly services proposal |
| 03/23/23 | J. Gillis | 0.10 | 17.00 | Confer with staff regarding FY 24 budget documents |
| 03/23/23 | L. Whelan | 0.20 | 58.00 | Confer with staff regarding landscape maintenance scope; confer with staff regarding FY 24 assessment documents |
| 03/28/23 | J. Gillis | 0.60 | 102.00 | Prepare FY 24 proposed budget resolution, published notice, mailed notice and affidavit of mailing |
| 03/30/23 | J. Gillis | 0.10 | 17.00 | Confer with staff regarding timeline of mailed notice for FY 24 budget adoption |
| 03/30/23 | L. Whelan | 0.30 | 87.00 | Review draft FY 24 budget documents |
| 03/31/23 | L. Whelan | 0.10 | 29.00 | Confer with staff regarding agenda items for April board meeting |
| TOTAL HOURS | | 11.00 | | |

KUTAK ROCK LLP

Belmont II CDD

April 18, 2023

Client Matter No. 2223-1

Invoice No. 3209046

Page 3

TOTAL FOR SERVICES RENDERED \$2,985.50

DISBURSEMENTS

Meals 14.83

Travel Expenses 111.63

TOTAL DISBURSEMENTS 126.46

TOTAL CURRENT AMOUNT DUE \$3,111.96

KUTAK ROCK LLP

TALLAHASSEE, FLORIDA

Telephone 404-222-4600

Facsimile 404-222-4654

Federal ID 47-0597598

April 18, 2023

Check Remit To:

Kutak Rock LLP

PO Box 30057

Omaha, NE 68103-1157

ACH/Wire Transfer Remit To:

ABA #104000016

First National Bank of Omaha

Kutak Rock LLP

A/C # 24690470

Reference: Invoice No. 3209046

Client Matter No. 2223-1

Notification Email: eftgroup@kutakrock.com

Ms. Debby Bayne-Wallace
Belmont II CDD
Rizzetta & Company, Inc.
Suite 115
12750 Citrus Park Lane
Tampa, FL 33625

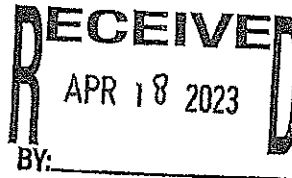

1,310,513.315

Invoice No. 3209046

2223-1

Re: General Counsel

For Professional Legal Services Rendered

| | | | | |
|----------|-----------|------|--------|---|
| 03/01/23 | J. Gillis | 0.40 | 68.00 | Confer with staff and prepare revisions to license agreement for gate installation and maintenance with Belmont Townhomes Association |
| 03/02/23 | J. Gillis | 0.30 | 51.00 | Coordinate response to auditor letter |
| 03/02/23 | L. Whelan | 0.10 | 29.00 | Review revised HOA gate installation agreement |
| 03/03/23 | L. Whelan | 0.10 | 29.00 | Confer with Ms. Wallace regarding revised scope for gate installation matter |
| 03/04/23 | W. Haber | 0.50 | 192.50 | Monitor 2023 legislative session for legislation pertaining to or affecting District |
| 03/07/23 | L. Whelan | 0.10 | 29.00 | Review draft meeting agenda for March board meeting |
| 03/10/23 | L. Whelan | 1.30 | 377.00 | Review tentative agenda for joint board meeting; review draft |

KUTAK ROCK LLP

Belmont II CDD

April 18, 2023

Client Matter No. 2223-1

Invoice No. 3209046

Page 2

| | | | | |
|-------------|-----------|-------|--------|---|
| | | | | interlocal invoice for FY 22 and confer with Ms. Wallace regarding same |
| 03/13/23 | L. Whelan | 0.10 | 29.00 | Confer with staff regarding agenda package for joint board meeting |
| 03/15/23 | L. Whelan | 0.40 | 116.00 | Prepare for March board meeting |
| 03/16/23 | L. Whelan | 0.10 | 29.00 | Confer with Ms. Evans regarding status of amenity payment to Belmont CDD |
| 03/20/23 | L. Whelan | 1.70 | 493.00 | Review February financial statements; travel to joint and regular March board meeting |
| 03/21/23 | L. Whelan | 3.30 | 957.00 | Attend regular March and joint board meetings; return travel |
| 03/22/23 | J. Gillis | 0.60 | 102.00 | Follow up from Board meeting; prepare amendment to Sitex agreement for midge fly treatment services |
| 03/22/23 | L. Whelan | 0.60 | 174.00 | Follow-up from March regular and joint board meeting; review draft amendment to midge fly services proposal |
| 03/23/23 | J. Gillis | 0.10 | 17.00 | Confer with staff regarding FY 24 budget documents |
| 03/23/23 | L. Whelan | 0.20 | 58.00 | Confer with staff regarding landscape maintenance scope; confer with staff regarding FY 24 assessment documents |
| 03/28/23 | J. Gillis | 0.60 | 102.00 | Prepare FY 24 proposed budget resolution, published notice, mailed notice and affidavit of mailing |
| 03/30/23 | J. Gillis | 0.10 | 17.00 | Confer with staff regarding timeline of mailed notice for FY 24 budget adoption |
| 03/30/23 | L. Whelan | 0.30 | 87.00 | Review draft FY 24 budget documents |
| 03/31/23 | L. Whelan | 0.10 | 29.00 | Confer with staff regarding agenda items for April board meeting |
| TOTAL HOURS | | 11.00 | | |

KUTAK ROCK LLP

Belmont II CDD

April 18, 2023

Client Matter No. 2223-1

Invoice No. 3209046

Page 3

TOTAL FOR SERVICES RENDERED \$2,985.50

DISBURSEMENTS

Meals 14.83

Travel Expenses 111.63

TOTAL DISBURSEMENTS 126.46

TOTAL CURRENT AMOUNT DUE \$3,111.96

INVOICE

Rockstar Party Productions
United States

BILL TO
Aberdeen CDD
Kate Trivelpiece

904-217-0925
Kate.Trivelpiece@fsresidential.com

Invoice Number: 3
Invoice Date: April 6, 2023
Payment Due: April 8, 2023
Amount Due (USD): \$450.00

| Items | Quantity | Price | Amount |
|-----------------------------|----------|----------|----------|
| DJ Aberdeen Spring Festival | 1 | \$450.00 | \$450.00 |
| Total: | | | \$450.00 |

RECEIVED
APR 11 2023
BY: _____

Amount Due (USD): \$450.00

*Special Events
300,572.49400
KS*



PAYMENT ADDRESS:
Turner Pest Control LLC • P.O. Box 952503 • Atlanta, Georgia 31192-2503
904-355-5300 • Fax: 904-353-1499 • Toll Free: 800-226-6385 • turnerpest.com

Turner Pest Control LLC
P.O. Box 952503
Atlanta, GA 31192-2503
904-355-5300

Service Slip/Invoice

| | |
|----------|-----------|
| INVOICE: | 617159963 |
| DATE: | 4/5/2023 |
| ORDER: | 617159963 |

Bill To: [139845]
Aberdeen
Aberdeen - CDD
C/O Government Services
475 W. Town Place - Suite 114
Saint Augustine, FL 32092

Work Location: [139845] 904-626-0375
Aberdeen
Aberdeen - CDD
110 Flower Of Scotland Ave
Saint Johns, FL 32259-6937

1,320.538.45926

| Work Date | Time | Target Pest | Technician | Time In |
|-----------|----------|-------------|------------|----------|
| 4/5/2023 | 02:02 PM | | | 02:02 PM |

| Purchase Order | Terms | Last Service | Map Code | Time Out |
|----------------|--------|--------------|----------|----------|
| | NET 30 | 4/5/2023 | 121:C5 | 02:42 PM |

| Service | Description | Price |
|---------|-------------|-------|
|---------|-------------|-------|

| | | |
|------|---|--------------------------|
| CPCM | Commercial Pest Control - Monthly Service | \$109.15 |
| | | SUBTOTAL \$109.15 |
| | | TAX \$0.00 |
| | | AMT. PAID \$0.00 |
| | | TOTAL \$109.15 |

AMOUNT DUE: \$109.15

RECEIVED
APR 06 2023
BY: _____

TECHNICIAN SIGNATURE

CUSTOMER SIGNATURE

Balances outstanding over 30 days from the date of service may be subject to a late fee of the lesser of 1.5% per month (18% per year) or the maximum allowed by law. Customer agrees to pay accrued expenses in the event of collection.

I hereby acknowledge the satisfactory completion of all services rendered and agree to pay the cost of services as specified above.

PLEASE PAY FROM THIS INVOICE

Invoice

 **Unicorn**
 Web Development
 P.O. Box 762,
 Middleburg, FL 32050

| | |
|----------|-----------|
| Date | Invoice # |
| 4/1/2023 | 2917 |

| |
|--|
| Bill To |
| GOVERNMENTAL MANAGEMENT SERVICES, LLC ABERDEEN CDD 475 WEST TOWN PLACE, SUITE 114 WORLD GOLF VILLAGE ST. AUGUSTINE, FL 32092 |

RECEIVED
 APR 07 2023
 BY: _____

| | | |
|----------|-------|---------|
| P.O. No. | Terms | Project |
| | | |

| Quantity | Description | Rate | Amount |
|--------------|--|--------|----------|
| 1 | MONTHLY MAINTENANCE AND NEWSLETTER - ABERDEEN CDD 1,320,538,45919 | 150.00 | 150.00 |
| Total | | | \$150.00 |

| CHECK DATE | VEND# |INVOICE..... DATE INVOICE | ...EXPENSED TO... YRMO DPT ACCT# SUB SUBCLASS | VENDOR NAME | STATUS | AMOUNT |CHECK..... AMOUNT # |
|--------------------|-------|-----------------------------------|--|-------------------------------|--------|-----------|----------------------------|
| 4/07/23 | 00120 | 3/29/23 7961 | 202303 600-53800-60000 FINAL PMT CANOPY POOL | ADVANCED AWNING & DESIGN, LLC | * | 12,745.00 | 12,745.00 000144 |
| TOTAL FOR BANK B | | | | | | 12,745.00 | |
| TOTAL FOR REGISTER | | | | | | 12,745.00 | |

Check Approval Form

Capital Reserve

Date: April 7, 2023

District: Aberdeen CDD

Fund Code: 33

Beginning Check #: 144

Ending Check #: 144

Total Amount of Checks: \$ 12,745.00 New Balance

Balance in Account***: \$ 460,263.89 \$ 447,518.89

Recent Deposits: _____

Prepared by: Todd R. Polvere

Signature: 

Approved by: Jim Oliver

Signature: _____

BANK B: CAPITAL RESERVE FUND

| VEND NO. | Invoice Date | Vendor Inv. No. | General Ledger# | St | Cr | DUE DATE | GROSS AMOUNT | DISC AMOUNT | NET AMOUNT | PO# | CHECK NO. |
|----------|--------------|-------------------------------|-----------------|----|----|----------|--------------|-------------|------------|-----|-----------|
| 00120 | 32923 7961 | 033-600-53800-60000 | | | | 32923 | 12,745.00 | .00 | 12,745.00 | | |
| | | FINAL PMT CANOPY POOL | | | | | | | | | |
| | | ADVANCED AWNING & DESIGN, LLC | | | | | 12,745.00 | .00 | 12,745.00 | | 000144 |
| | | | | | | | 12,745.00 | .00 | 12,745.00 | | |
| | | | | | | | | | | | |
| | | | | | | | 12,745.00 | .00 | 12,745.00 | | |

ABER ABERDEEN TPOLVERE



Advanced Awning & Design, LLC
 2155 Corporate Square Blvd.
 Building 100
 Jacksonville, FL 32216

Invoice

| | |
|-----------|-----------|
| DATE | INVOICE # |
| 3/29/2023 | 7961 |

| |
|------------------------------|
| BILL TO |
| Jay Parker FS Residential |

| |
|--|
| SHIP TO |
| Aberdeen CDD 110 Flower of Scotland ave. St. Johns, FL 32259 |

| P.O. NUMBER | TERMS | REP | SHIP | VIA | PROJECT | |
|-------------|--------|---|-----------|-----------|-------------------------------|-----------|
| | C.O.D. | JMS | 3/29/2023 | Installed | Aberdeen Community Develop... | |
| QTY | ITEM | DESCRIPTION | | | PRICE EACH | AMOUNT |
| 1 | CANOPY | CUSTOM CANOPY FOR POOL EQUIPMENT AREA; 10 YR WEATHER CHEK VINYL, ENGINEERING AND PERMITTING <i>33.600, 538.600</i> | | | 25,490.00 | 25,490.00 |
| | | | | | | |

| | | |
|--|-------------------------|--------------|
| Terms - C.O.D. Thank you for your business. | Total | \$25,490.00 |
| | Payments/Credits | -\$12,745.00 |
| | Balance Due | \$12,745.00 |

| | | | |
|------------|--------------|----------------------------|-------------------------|
| Phone # | Fax # | E-mail | Web Site |
| 9047245567 | 904-724-1323 | ACCOUNTING@ADVANCED-AWN... | www.advanced-awning.com |