

ABERDEEN

Community Development District

APRIL 25, 2023

AGENDA

Aberdeen
Community Development District

475 West Town Place

Suite 114

St. Augustine, Florida 32092

District Website: www.AberdeenCDD.com

April 18, 2023

Board of Supervisors
Aberdeen Community Development District

Dear Board Members:

The Aberdeen Community Development District Meeting is scheduled for **Tuesday, April 25, 2023 at 4:00 p.m.** at the Aberdeen Amenity Center, 110 Flower of Scotland Avenue, St. Johns, Florida 32259.

Following is the advance agenda for the meeting:

- I. Roll Call
- II. Public Comments (*regarding agenda items below*)
- III. Consideration of Proposals (as provided by staff)
 - A. Slide Quotes
 - B. Bike Rack Proposals
 - C. Furniture Proposals for Fitness Center Area
 - D. ADA Pool Lift Proposals
- IV. Presentation of Preliminary Fiscal Year 2024 Budget
- V. Staff Reports
 - A. Attorney
 - B. Engineer
 - C. Manager

- D. Operation Manager
- E. Amenity Center Manager - Report
- VI. Supervisor's Request and Public Comments
- VII. Approval of Consent Agenda
 - A. Approval of the Minutes of the March 28, 2023 Meeting
 - B. Balance Sheet as of March 31, 2023 and Statement of Revenues and Expenses for the Period Ending March 31, 2023
 - C. Assessment Receipt Schedule
 - D. Approval of Check Register
- VIII. Next Scheduled Meeting – 05/23/23 @ **6:00 p.m.**@ Aberdeen Amenity Center
- IX. Adjournment

THIRD ORDER OF BUSINESS

A.



**Recreational
Products & Services**

10271 Deer Run Farms Road, Suite 1
Fort Myers, FL 33966
(239) 791-2400 (239) 791-2401 fax
(888) 886-3757 toll free
www.playmoreonline.com

QUOTATION

04/11/23
Job Number: 18009

Client: Aberdeen CDD
110 Flower Of Scotland Ave.
St. Johns FL 32259

Revision: A
Job: Aberdeen PG Parts
110 Flower Of Scotland Ave.
St. Johns FL 32259

Contact: Kate Trivelpiece Phone: 904-217-0925 Fax: Email: Kate.Trivelpiece@fsresidential.com

Sales Rep: Mary Cyr Terms: Due With Order

Item	Description	Quantity	Cost	Subtotal
1 EQUIPMENT				
ZZCH3206	SLITHER SLIDE 2.0 ENTRANCE & EXIT	1	\$1,791.00	\$1,791.00
ZZUN3218	SLITHER SLIDE 2.0 (LEFT 120° SEC)	1	\$982.00	\$982.00
ZZUN3217	SLITHER SLIDE 2.0 (RIGHT 120° SEC)	1	\$982.00	\$982.00
ZZUN3249	SLITHER SLIDE 2.0 SUPP LEG 3'-6"	1	\$268.00	\$268.00

ALL HARDWARE INCLUDED IN ABOVE PRICING.

ORIGINAL SLIDE IS OBSOLETE & REPLACED BY THE ABOVE SLIDE PIECES.
THEREFORE, ALL ORIGINAL PARTS & FOOTINGS MUST BE REPLACED.

COLORS: POST PAINT SAND, PLASTICS BEIGE, COMPONENTS BROWN

COLORS MAY NOT MATCH EXACTLY DUE TO MANUFACTURER
COLOR CHANGE IN 2017.

Subtotal: \$4,023.00

2 FREIGHT

Freight	PLAYWORLD FREIGHT	1	\$297.00	\$297.00
---------	-------------------	---	----------	----------

Subtotal: \$297.00

Notes: ORIGINAL SO# 0808368

DOES NOT INCLUDE ANY ADDITIONAL HARDWARE, TOOLS, INSTALLATION OR OTHER
PRODUCTS & SERVICES.

REPLACEMENT PARTS ARE BASED ON INFORMATION RECEIVED FROM THE CUSTOMER.
PLAYMORE WILL NOT BE RESPONSIBLE FOR ANY ERRORS OR OMISSIONS TO
REPLACEMENT PARTS.

PLAYMORE

Recreational Products & Services

10271 Deer Run Farms Road, Suite 1
Fort Myers, FL 33966
(239) 791-2400 (239) 791-2401 fax
(888) 886-3757 toll free
www.playmoreonline.com

QUOTATION

04/11/23

Job Number: 18009
Revision: A

Client: Aberdeen CDD
110 Flower Of Scotland Ave.
St. Johns FL 32259

Job: Aberdeen PG Parts
110 Flower Of Scotland Ave.
St. Johns FL 32259

Item	Description	Quantity	Cost	Subtotal
3 SALES TAX				
	ST. JOHNS COUNTY SALES TAX - 6.5%	1	\$261.50	\$261.50
	SALES TAX WILL BE REVERSED WHEN TAX EXEMPT CERTIFICATE IS RECEIVED.			
		Subtotal:		\$261.50
4 INSTALLATION				
PSI Installation	Installation of Playworld Equipment *Includes removal of damaged slide*	1	\$2,250.00	\$2,250.00
	DISPOSAL ON SITE			
		Subtotal:		\$2,250.00
		Grand Totals:		\$6,831.50

PLAYMORE

Recreational Products & Services

10271 Deer Run Farms Road, Suite 1
Fort Myers, FL 33966
(239) 791-2400 (239) 791-2401 fax
(888) 886-3757 toll free
www.playmoreonline.com

QUOTATION

04/11/23

Job Number: 18009
Revision: A

Client: Aberdeen CDD
110 Flower Of Scotland Ave.
St. Johns FL 32259

Job: Aberdeen PG Parts
110 Flower Of Scotland Ave.
St. Johns FL 32259

General Terms:

Acceptance by a signature, purchase order, or contract based on this proposal indicates that you are in full agreement with all terms and conditions of this proposal, including the following:

- Prices are valid for 30 days, unless otherwise noted. After 30 days, prices are subject to change without notice.
- Sales Tax will be charged unless a valid Sales Tax Exemption Certificate is presented with order.
- Specify all colors and options in writing. Any discrepancies that arise due to oral selections will be the responsibility of the customer.
- If the customer is installing equipment, all equipment is to be installed per manufacturer's instructions and applicable guidelines.
- Installation, site work, permits, engineering, etc. are not included unless noted.

Building Permits:

Building permits are the responsibility of the owner. If a building permit is required for your project, the following options are available.

- Add 5% (minimum \$2,500) to the quotation/contract price. Playmore Recreational Products and Services will cover the costs of all the building permit fees and expeditor fees.
- Playmore Recreational Products and Services can assist the customer in obtaining their own permit. Customer is responsible for all fees directly to the permitting agency and/or the expediting company.

NOTE – All zoning, planning, health, environmental, architectural, etc. permits, reviews, and approvals are the responsibility of others as well as any required site plans or other supporting documents. If signed and sealed engineered drawings are needed for the installation of equipment, this will be included on the proposal. If it is omitted and later discovered necessary, the cost will be the responsibility of the customer.

Standard Services Include:

- Shipping Notification/Receiving Instructions
- Pre-Installation On-Site Meeting
- Public Utility Check (Sunshine State One Call)
- Accept Delivery and Unload Equipment
- Moving New Equipment at Job Site
- Layout of Equipment
- Installation of Equipment per Manufacturer's Instructions
- Trash Clean Up (Leave on site.)
- Post-Installation Walk Through
- Maintenance Explanation

Customer Responsibilities (unless otherwise noted in the applicable quotation/contract):

- Trash Disposal – Dumpsters or Off-Site Disposal.
- Accept Delivery and Unload Equipment if site is not ready.
 - \$1,000.00 Charge will apply if Customer wants Installers to Unload.
- Provide Area for Storage and Staging.
- Secure Site and Equipment.

PLAYMORE

Recreational Products & Services

10271 Deer Run Farms Road, Suite 1
Fort Myers, FL 33966
(239) 791-2400 (239) 791-2401 fax
(888) 886-3757 toll free
www.playmoreonline.com

QUOTATION

04/11/23

Job Number: 18009
Revision: A

Client: Aberdeen CDD
110 Flower Of Scotland Ave.
St. Johns FL 32259

Job: Aberdeen PG Parts
110 Flower Of Scotland Ave.
St. Johns FL 32259

Some Optional Responsibilities (Must be clearly outlined in the applicable quotation/contract):

- Removal of Existing Equipment.
- Site Preparation, Grading, Drainage Systems, etc.
- Private Utility Locates
- Engineered Drawings for Purchased Equipment.
- Other Permits or Engineered Drawings (i.e. zoning permits, environmental permits, site surveys, etc.)

***Any other responsibilities must be clearly outlined in the applicable quotation/contract.**

General Notes (All apply unless changes noted in quotation, purchase order, or contract)

Warranties. All equipment, surfacing, and installation is warranted by Playmore for a period of one year from substantial completion date. After one year, any additional manufacturer's warranties will remain in effect. Manufacturer's warranty claims to be processed by manufacturer. Playmore assumes no responsibility for these additional warranties.

Access/Utilities. Access must be provided to the installation area for heavy trucks and equipment. Access of equipment and personnel is the obligation of the customer to provide until the project is fully completed. We will take every precaution to avoid damage, however any damage caused by the normal installation of our product, such as to sod, concrete sidewalks, private underground utilities, etc., will be the responsibility of the customer, as will any additional costs associated with limiting damage, such as providing plywood over sod for access. If access is not reasonably close to the jobsite, any additional costs incurred due to having to transport materials and/or supplies will be the responsibility of the customer.

Rock/Foreign Object Clause. Most installations require digging of holes and footing equipment in concrete below finished grade. Removal of existing ground covers such as asphalt, concrete, tan bark, sand, pea gravel, wood fiber, rubber matting, poured-in-place rubber surfacing, or any other material that interferes or delays the digging of holes, is the responsibility of others, unless otherwise noted. If excessive underground obstructions such as rocks, coral, asphalt, concrete, pipes, drainage systems, root systems, water, or any other unknown obstructions are discovered, charges will be added to the original proposal.

Playground Surfacing. All playground equipment is to be installed over safety surfacing per CPSC guidelines and ASTM standards. If the customer contracts for something contrary to the guidelines, they are accepting all responsibility for any liability and future litigation that may arise.

Acceptance Signature: X Date: _____ P.O.#: _____



Proposed Date	APRIL 13, 2023
Expiration Date	MAY 13, 2023

Southern Recreation

Play for all ages

4060 Edison Avenue
 Jacksonville, Florida 32254
 Phone 904-387-4390 Fax 904-387-4391
terry@southernrecreation.com
www.southernrecreation.com

PROJECT NAME:
 Aberdeen Amenity Center

PROPOSED TO **Kate Trivelpiece**
 First Service Residential
 110 Flower of Scotland Ave.
 St. Johns, FL 32259
 904-217-0925
Kate.trivelpiece@fsresidential.com

BILL TO Same

SALESPERSON	SHIPPING METHOD	PAYMENT TERMS
Terry	Installed	Net 30

QTY	ITEM #	DESCRIPTION	UNIT PRICE	LINE TOTAL
1ea.		Installation of owner provided Playworld Systems Slide		1,800.00

Subtotal	1,800.00
Tax Rate	.07
Tax	Exempt
Freight	N/A
Installation	Included
Total Due	1,800.00

Terms and Conditions and Required Signature on next page.

Southern Recreation, Inc. Terms and Conditions

Payment A 50% deposit is required to begin project. The deposit is non-refundable. If equipment is refused when delivery is attempted you will be responsible for any resulting charges. A signed terms and condition and payment of the deposit indicates that you are in full agreement with all terms and conditions of this proposal including the following: Prices are valid for 30 days. After 30 days, prices are subject to change without notice. Sales tax will be charged unless a copy of a valid Sales tax exemption certificate is presented.

Balance of monies are due immediately upon completion and acceptance by the owner of the equipment and installation. Installation, site work, drainage, equipment removal, building permits, engineered drawings, etc. as listed below are not included unless specifically noted on the proposal.

Installation may include the following: Permitting if required for the State of Florida - State Certified Contractor CBC1252594

Site Preparation to include equipment removal, excavation, grading and drainage

Concrete work to include Curbing for containment and Sidewalks for accessibility

Installation of your Playground by *NPSI and Factory Certified Installers

Safety Surfacing as propose- Engineered Wood Fiber, Poured-In- Place Rubber Surfacing, Loose Fill Rubber or Synthetic Turf
Complete site clean up and playground inspection upon completion
*National Playground Safety Institute Certified Playground Safety Inspectors

Southern Recreation Responsibilities Southern Recreation (SR) is responsible for the acceptance of all freight deliveries that includes the installation of the equipment. All equipment will ship to our warehouse for acceptance and inventory. Equipment will be transported to the installation site on fully insured SR trucks and trailers. SR is responsible to secure the site and equipment while the installation is in progress. All equipment to be installed per CPSC and ASTM guidelines for proper spacing and elevations. SR is responsible for trash removal as a result of the installation

Owners Responsibilities Provide access to the installation site. Provide area for storage and staging if needed. Security at the installation site both during and after work hours. To provide sufficient input for equipment locations so as to properly install per the owners intent-

Note: All equipment installation must meet CPSC and ASTM guidelines for proper spacing. **SR WILL NOT INSTALL** any equipment outside of these spacing guidelines

Optional Responsibilities If a building permit is required, it is the responsibility of the owner to provide SR will all necessary documentation as needed-this would include an acceptable site plan, warranty deed (if needed), owners notarized signatures on permit and Notice of Commencement and all other documentation as required by the local building department of jurisdiction in order to execute the permit. Charges for permitting will include an administrative fee and actual permit cost. Any other SR responsibilities must be clearly outlined in the applicable proposal/contract

Access/Utilities Access will need to be provided to the installation area for heavy trucks and equipment. Access of equipment and personnel is the obligation of the customer to provide until the project is fully completed. We will take every precaution to avoid damage.

Rock/Foreign Object Clause Most installations require digging of holes and footing equipment in concrete below finished grade. Removal of existing ground covers such as asphalt, concrete, tan bark, sand, pea gravel, wood fiber, rubber matting, poured-in- place rubber surfacing, or any other material that interferes or delays the digging of holes, is the responsibility of others, unless otherwise noted. If excessive underground obstructions such as rock, coral, asphalt, concrete, pipes, drainage systems, root systems, water, or any other unknown obstructions are discovered, charges will be added to the original proposal.

Playground Surfacing All playground equipment is to be installed over safety surfacing per CPSC guidelines and ASTM standards. If the customer contracts for something contrary to the guidelines, they are accepting all responsibility for any liability and future litigation that may arise.

Signature of owner or owners rep indicates acceptance of the above terms and conditions

Authorized signature Terry Rogers Terry Rogers, President

Accepted by _____ Date _____

Billing Name and Address: _____ Billing Email: _____

Please sign and fill in the information where the project invoice will be billed to.



Southern Recreation, Inc.

4060 Edison Avenue, Jacksonville, Florida 32254

B.



Proposed Date	APRIL 17, 2023
Expiration Date	MAY 17, 2023

Southern Recreation

Play for all ages

4060 Edison Avenue
 Jacksonville, Florida 32254
 Phone 904-387-4390 Fax 904-387-4391
terry@southernrecreation.com
www.southernrecreation.com

PROJECT NAME:
 Aberdeen Amenity Center

PROPOSED TO **Kate Trivelpiece**
 First Service Residential
 110 Flower of Scotland Ave.
 St. Johns, FL 32259
 904-217-0925
Kate.trivelpiece@fsresidential.com

BILL TO Same

SALESPERSON	SHIPPING METHOD	PAYMENT TERMS
Terry	Installed	50% Deposit

QTY	ITEM #	DESCRIPTION	UNIT PRICE	LINE TOTAL
1ea.	627CIG	Seven Loop Bike Rack-Powder Coated-In Ground		899.00

Subtotal	899.00
Tax Rate	.07
Tax	Exempt
Freight	349.00
Installation	195.00
Total Due	1,443.00

Terms and Conditions and Required Signature on next page.

Southern Recreation, Inc. Terms and Conditions

Payment A 50% deposit is required to begin project. The deposit is non-refundable. If equipment is refused when delivery is attempted you will be responsible for any resulting charges. A signed terms and condition and payment of the deposit indicates that you are in full agreement with all terms and conditions of this proposal including the following: Prices are valid for 30 days. After 30 days, prices are subject to change without notice. Sales tax will be charged unless a copy of a valid Sales tax exemption certificate is presented.

Balance of monies are due immediately upon completion and acceptance by the owner of the equipment and installation. Installation, site work, drainage, equipment removal, building permits, engineered drawings, etc. as listed below are not included unless specifically noted on the proposal.

Installation may include the following: Permitting if required for the State of Florida - State Certified Contractor CBC1252594

Site Preparation to include equipment removal, excavation, grading and drainage

Concrete work to include Curbing for containment and Sidewalks for accessibility

Installation of your Playground by *NPSI and Factory Certified Installers

Safety Surfacing as propose- Engineered Wood Fiber, Poured-In- Place Rubber Surfacing, Loose Fill Rubber or Synthetic Turf
Complete site clean up and playground inspection upon completion
*National Playground Safety Institute Certified Playground Safety Inspectors

Southern Recreation Responsibilities Southern Recreation (SR) is responsible for the acceptance of all freight deliveries that includes the installation of the equipment. All equipment will ship to our warehouse for acceptance and inventory. Equipment will be transported to the installation site on fully insured SR trucks and trailers. SR is responsible to secure the site and equipment while the installation is in progress. All equipment to be installed per CPSC and ASTM guidelines for proper spacing and elevations. SR is responsible for trash removal as a result of the installation

Owners Responsibilities Provide access to the installation site. Provide area for storage and staging if needed. Security at the installation site both during and after work hours. To provide sufficient input for equipment locations so as to properly install per the owners intent-

Note: All equipment installation must meet CPSC and ASTM guidelines for proper spacing. **SR WILL NOT INSTALL** any equipment outside of these spacing guidelines

Optional Responsibilities If a building permit is required, it is the responsibility of the owner to provide SR will all necessary documentation as needed-this would include an acceptable site plan, warranty deed (if needed), owners notarized signatures on permit and Notice of Commencement and all other documentation as required by the local building department of jurisdiction in order to execute the permit. Charges for permitting will include an administrative fee and actual permit cost. Any other SR responsibilities must be clearly outlined in the applicable proposal/contract

Access/Utilities Access will need to be provided to the installation area for heavy trucks and equipment. Access of equipment and personnel is the obligation of the customer to provide until the project is fully completed. We will take every precaution to avoid damage.

Rock/Foreign Object Clause Most installations require digging of holes and footing equipment in concrete below finished grade. Removal of existing ground covers such as asphalt, concrete, tan bark, sand, pea gravel, wood fiber, rubber matting, poured-in- place rubber surfacing, or any other material that interferes or delays the digging of holes, is the responsibility of others, unless otherwise noted. If excessive underground obstructions such as rock, coral, asphalt, concrete, pipes, drainage systems, root systems, water, or any other unknown obstructions are discovered, charges will be added to the original proposal.

Playground Surfacing All playground equipment is to be installed over safety surfacing per CPSC guidelines and ASTM standards. If the customer contracts for something contrary to the guidelines, they are accepting all responsibility for any liability and future litigation that may arise.

Signature of owner or owners rep indicates acceptance of the above terms and conditions

Authorized signature Terry Rogers Terry Rogers, President

Accepted by _____ Date _____

Billing Name and Address: _____ Billing Email: _____

Please sign and fill in the information where the project invoice will be billed to.



Southern Recreation, Inc.

4060 Edison Avenue, Jacksonville, Florida 32254

C.



Taylor & Associates, Inc.

940 Opie Arnold Road
Limestone, TN 37681
Toll Free Direct: 855-734-3580

Quotation

Date	Quote #
4/14/2023	1719

Bill To
Aberdeen AP 110 Flower of Scotland Ave St Johns, FL 32259 904-217-0925

Ship To
Aberdeen Kate 110 Flower of Scotland Ave St Johns, FL 32259 904-217-0925

www.TaylorIncorporated.com

P.O. Number	Terms	Rep	Via
	See Terms Below	Renna Levert	Best Way

Quantity	Item Code	Description	Price Each	Amount
12	I-49	Island Breeze Sling Dining Chair	156.00	1,872.00
3	7342D	42" Aluminum Decorative Top Dining Table with No Hole	488.80	1,466.40
1	TATL-355CU	Atlantis Deep Seating Couch with Plasma Cut Seat	2,405.00	2,405.00
2	TATL-50CU	Atlantis Deep Seating Club Chair with Plasma Cut Seat	783.90	1,567.80
1	TAH-CoffeeTable	24" x 42: Sled Based Press Break Coffee Table	546.00	546.00
Terms: Prepay via Company Check or Wire Transfer Colors: Frame - Table Top Pattern - Sling Fabric - Cushion Fabric - Current Lead Time 20-23 weeks				
1	S & H	Shipping & Handling Charges (Drop Ship Only) - Lift Gate, Inside Delivery, Heads Up Call are available for addition cost.	350.00	350.00



Sales Do Not Include Sales Tax, Purchaser Responsible For All Local, State & Use Tax Unless Otherwise Indicated. Quote Good For 30 Days. To process your order, please sign, date below and return via email.
Thank You So Very Much For Your Business!!
Approved By: _____

Date: _____

Sales Tax (0.0%)

\$0.00

Total

\$8,207.20



Taylor & Associates, Inc.

940 Opie Arnold Road
Limestone, TN 37681
Toll Free Direct: 855-734-3580

Quotation

Date	Quote #
4/14/2023	1720

Bill To
Aberdeen AP 110 Flower of Scotland Ave St Johns, FL 32259 904-217-0925

Ship To
Aberdeen Kate 110 Flower of Scotland Ave St Johns, FL 32259 904-217-0925

www.TaylorIncorporated.com

P.O. Number	Terms	Rep	Via	
	See Terms Below	Renna Levert	Best Way	
Quantity	Item Code	Description	Price Each	Amount
12	C-50C	Classic Stacking Dining Chair, 1" Round Extrusion, Cross Strap	147.68	1,772.16
3	7342D	42" Aluminum Decorative Top Dining Table with No Hole	523.12	1,569.36
1	TATL-355CU	Atlantis Deep Seating Couch with Plasma Cut Seat	2,405.00	2,405.00
2	TATL-50CU	Atlantis Deep Seating Club Chair with Plasma Cut Seat	783.90	1,567.80
1	TAH-CoffeeTable	24" x 42: Sled Based Press Break Coffee Table	546.00	546.00
Terms: Prepay via Company Check or Wire Transfer Colors: Frame - Table Top Pattern - Vinyl Strap - Cushion Fabric - Current Lead time - 20-23 weeks				
1	S & H	Shipping & Handling Charges (Drop Ship Only) - Lift Gate, Inside Delivery, Heads Up Call are available for addition cost.	350.00	350.00



Sales Do Not Include Sales Tax, Purchaser Responsible For All Local, State & Use Tax Unless Otherwise Indicated. Quote Good For 30 Days. To process your order, please sign, date below and return via email.
Thank You So Very Much For Your Business!!
Approved By: _____

Date: _____

Sales Tax (0.0%)

\$0.00

Total

\$8,210.32

Design Top Table Patterns



Pattern A - Solid

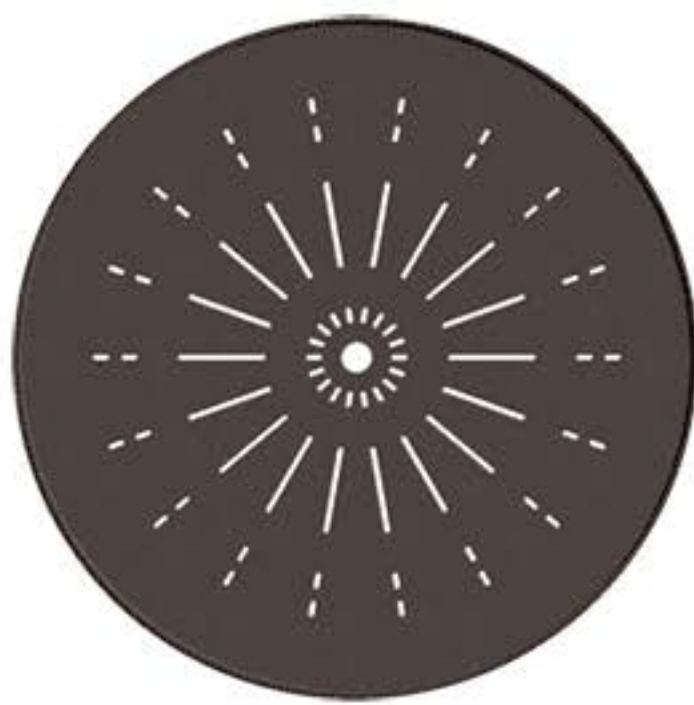

Pattern B - Mayan

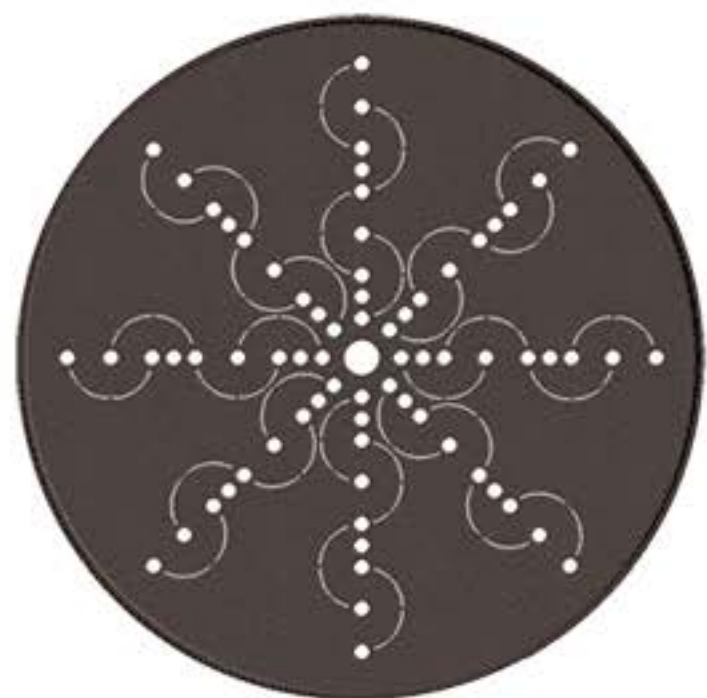

Pattern C - Crop Circle

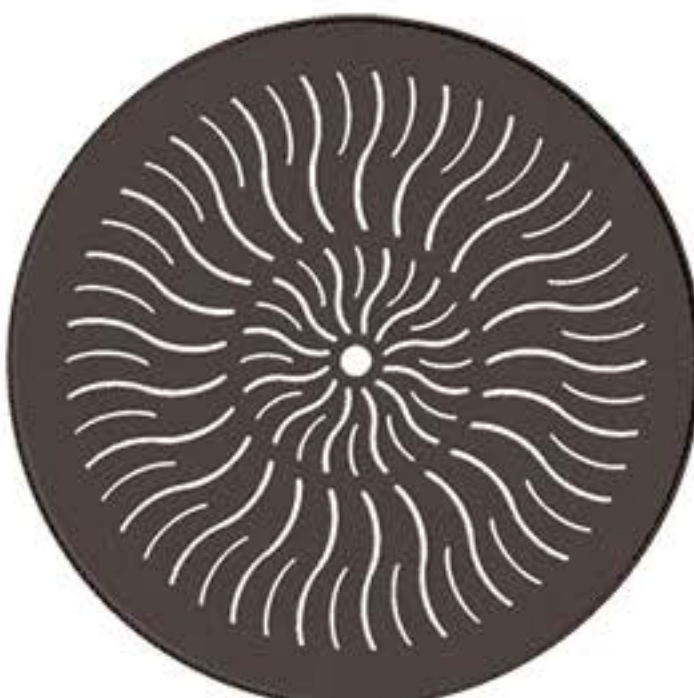

Pattern D - Sunfire

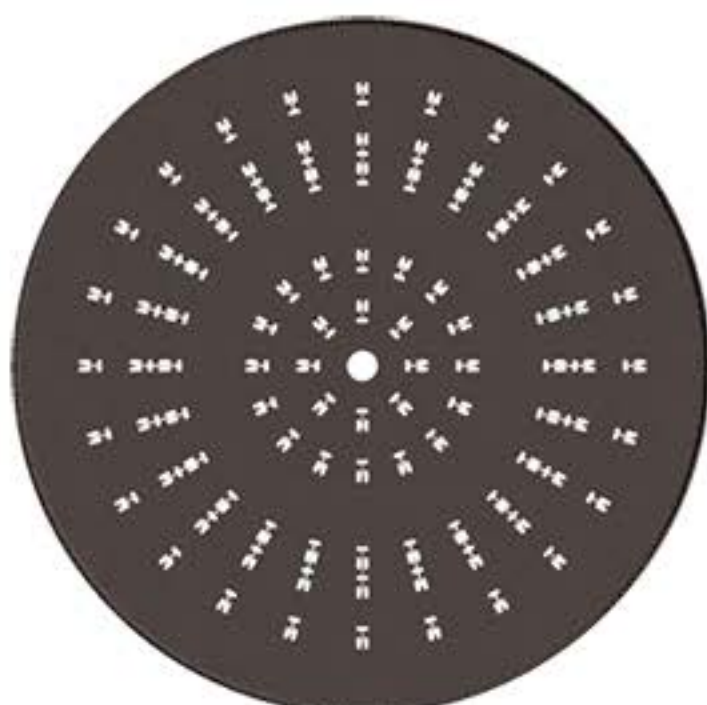

Pattern E - Enterprise

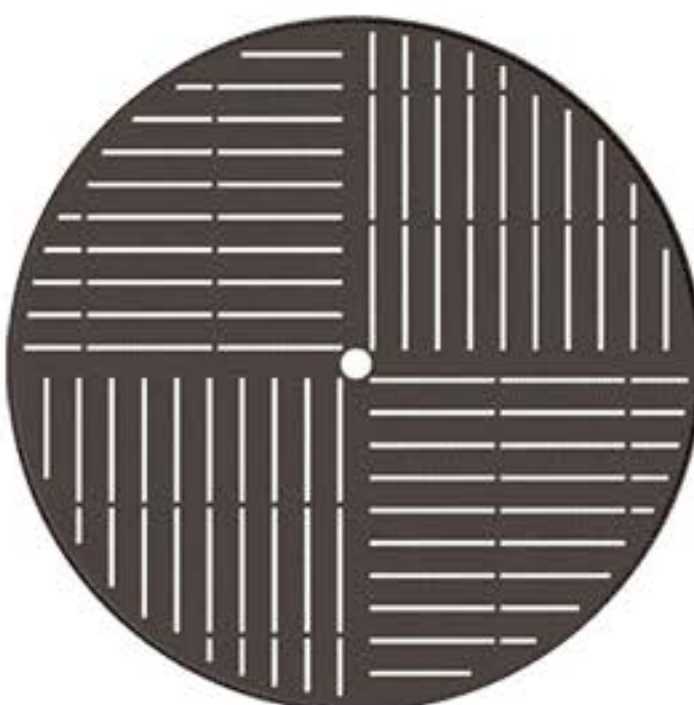

Pattern F - Boardwalk



Phone: (877) 646-6320
 Fax : (386) 437-6652

Quote

PO Box 2390
 Bunnell, FL 32110

A Furniture Leisure Web Store

Date	Quote No.
4/12/2023	PFS18406

Bill To
Aberdeen CDD Kate Trivelpiece 110 Flower of Scotland Ave. St. Johns, FL 32259

Ship To
Aberdeen CDD Kate Trivelpiece 110 Flower of Scotland Ave. St. Johns, FL 32259 USA

P.O. No.	Rep	Terms
	KC	50%Deposit/Net

Item	Description	Qty	Cost	Total
WT4218AU	42" Round Acrylic Top Dining Table with umbrella hole., 1 1/2" x 3/4" Flat Tubing Frame. 30lbs. Frame Color: Bronze Age List: \$539.95	3	450.00	1,350.00
W0350CW	St. Maarten Vinyl Strap Cross Weave Dining Arm Chair with Powder Coated Aluminum Frame, Stacking, 2" Vinyl Straps. 17"SH. Frame Color: ; Strap Color:	12	160.00	1,920.00
W3055	Barcelona Deep Seating Lounge Chair, All Aluminum Frame, Boxed Style Cushion, 33"W x 29"D, 19"SH. Frame Color: Cushion Color:	2	750.00	1,500.00
W30155	Barcelona Deep Seating Modular Center Piece (armless) with Powder Coated Aluminum Frame. Frame Color: Cushion Color:	1	750.00	750.00

All first time orders and orders up to \$24,999.99 require a 50% deposit, all orders \$25,000.00 and above require a 75% deposit. The Balance is due once the order ships. Due to Credit Card Processing guidelines, all Credit Card purchases will be processed for the full amount within 7 days of purchase. Orders will not be processed until the credit is approved by Furniture Leisure, Inc. All Custom Orders (made to the customer's specifications) require payment in advance and are non-cancelable and non-returnable. A 25% restocking fee plus all shipping costs are required to return stock merchandise. Customer is responsible for organizing and payment of return freight. Returns must receive a "Return Authorization" from Furniture Leisure, Inc. prior to shipping. All Returns must be received in the original cartons and in new condition.

Subtotal

Sales Tax (0.0%)

Order Total

The manufacturer of merchandise purchased from Furniture Leisure, Inc. warrants all products. Written warranties are available upon request. Furniture Leisure, Inc. assumes no responsibility to extend, alter, or modify any product warranty.

Furniture Leisure, Inc. will be held harmless against all claims of liability resulting from receiving, installation and use of these products. All Shipments are scheduled ASAP "as soon as possible". All effort will be made to expedite, however the purchaser acknowledges no arrival dates are guaranteed. Customer agrees to pay reasonable collection costs allowed by law and/or attorneys fees incurred in connection with the collection of this transaction. The venue for any litigation with Furniture Leisure, Inc will be Flagler County, FL.

Receiving, Offloading, Assembly, Placement of Furniture, Installation, and Removal of Packing Materials of the merchandise is solely the customer's responsibility and is not included in the above price.

Signature _____

Title _____ Date _____

sales@poolfurnituresupply.com

www.poolfurnituresupply.com



Phone: (877) 646-6320
 Fax : (386) 437-6652

Quote

PO Box 2390
 Bunnell, FL 32110

A Furniture Leisure Web Store

Date	Quote No.
4/12/2023	PFS18406

Bill To
Aberdeen CDD Kate Trivelpiece 110 Flower of Scotland Ave. St. Johns, FL 32259

Ship To
Aberdeen CDD Kate Trivelpiece 110 Flower of Scotland Ave. St. Johns, FL 32259 USA

P.O. No.	Rep	Terms
	KC	50%Deposit/Net

Item	Description	Qty	Cost	Total
W3055LR	Barcelona Deep Seating Left or Right Modular Sectional Piece with Powder Coated Aluminum Frame. Side: Left Frame Color: Cushion Color:	1	750.00	750.00
W3055LR	Barcelona Deep Seating Left or Right Modular Sectional Piece with Powder Coated Aluminum Frame. Side: Right Frame Color: Cushion Color:	1	750.00	750.00
WT2648-25SN	26" x 48" Rectangular Coffee Table, Newport MGP Top with Aluminum Base, 18 H, 32 lbs. Frame Color: Top Color:	1	450.00	450.00

All first time orders and orders up to \$24,999.99 require a 50% deposit, all orders \$25,000.00 and above require a 75% deposit. The Balance is due once the order ships. Due to Credit Card Processing guidelines, all Credit Card purchases will be processed for the full amount within 7 days of purchase. Orders will not be processed until the credit is approved by Furniture Leisure, Inc. All Custom Orders (made to the customer's specifications) require payment in advance and are non-cancelable and non-returnable. A 25% restocking fee plus all shipping costs are required to return stock merchandise. Customer is responsible for organizing and payment of return freight. Returns must receive a "Return Authorization" from Furniture Leisure, Inc. prior to shipping. All Returns must be received in the original cartons and in new condition.

Subtotal

Sales Tax (0.0%)

Order Total

The manufacturer of merchandise purchased from Furniture Leisure, Inc. warrants all products. Written warranties are available upon request. Furniture Leisure, Inc. assumes no responsibility to extend, alter, or modify any product warranty.

Furniture Leisure, Inc. will be held harmless against all claims of liability resulting from receiving, installation and use of these products. All Shipments are scheduled ASAP "as soon as possible". All effort will be made to expedite, however the purchaser acknowledges no arrival dates are guaranteed. Customer agrees to pay reasonable collection costs allowed by law and/or attorneys fees incurred in connection with the collection of this transaction. The venue for any litigation with Furniture Leisure, Inc will be Flagler County, FL.

Receiving, Offloading, Assembly, Placement of Furniture, Installation, and Removal of Packing Materials of the merchandise is solely the customer's responsibility and is not included in the above price.

Signature _____

Title _____ Date _____

sales@poolfurnituresupply.com

www.poolfurnituresupply.com



Phone: (877) 646-6320
 Fax : (386) 437-6652

Quote

PO Box 2390
 Bunnell, FL 32110

A Furniture Leisure Web Store

Date	Quote No.
4/12/2023	PFS18406

Bill To
Aberdeen CDD Kate Trivelpiece 110 Flower of Scotland Ave. St. Johns, FL 32259

Ship To
Aberdeen CDD Kate Trivelpiece 110 Flower of Scotland Ave. St. Johns, FL 32259 USA

P.O. No.	Rep	Terms
	KC	50%Deposit/Net

Item	Description	Qty	Cost	Total
S&H	Shipping and Handling. Commercial Delivery Curbside - Delivery does not include offloading freight. Lift Gate and 24 hr Call Ahead are requested for all applicable orders but are not guaranteed. - The delivery address must have ample room for a 53' semi truck to enter and turn around or exit the property without incident or obstacle. Notify your Sales Rep if a smaller truck is required. - Certain products will ship unassembled. Delivery does not include assembly, installation, placement of furniture, or removal of packing materials.		818.62	818.62

All first time orders and orders up to \$24,999.99 require a 50% deposit, all orders \$25,000.00 and above require a 75% deposit. The Balance is due once the order ships. Due to Credit Card Processing guidelines, all Credit Card purchases will be processed for the full amount within 7 days of purchase. Orders will not be processed until the credit is approved by Furniture Leisure, Inc. All Custom Orders (made to the customer's specifications) require payment in advance and are non-cancelable and non-returnable. A 25% restocking fee plus all shipping costs are required to return stock merchandise. Customer is responsible for organizing and payment of return freight. Returns must receive a "Return Authorization" from Furniture Leisure, Inc. prior to shipping. All Returns must be received in the original cartons and in new condition.

Subtotal

Sales Tax (0.0%)

Order Total

The manufacturer of merchandise purchased from Furniture Leisure, Inc. warrants all products. Written warranties are available upon request. Furniture Leisure, Inc. assumes no responsibility to extend, alter, or modify any product warranty.

Furniture Leisure, Inc. will be held harmless against all claims of liability resulting from receiving, installation and use of these products. All Shipments are scheduled ASAP "as soon as possible". All effort will be made to expedite, however the purchaser acknowledges no arrival dates are guaranteed. Customer agrees to pay reasonable collection costs allowed by law and/or attorneys fees incurred in connection with the collection of this transaction. The venue for any litigation with Furniture Leisure, Inc will be Flagler County, FL.

Receiving, Offloading, Assembly, Placement of Furniture, Installation, and Removal of Packing Materials of the merchandise is solely the customer's responsibility and is not included in the above price.

Signature _____

Title _____ Date _____

sales@poolfurnituresupply.com

www.poolfurnituresupply.com



Phone: (877) 646-6320
 Fax : (386) 437-6652

Quote

PO Box 2390
 Bunnell, FL 32110

A Furniture Leisure Web Store

Date	Quote No.
4/12/2023	PFS18406

Bill To
Aberdeen CDD Kate Trivelpiece 110 Flower of Scotland Ave. St. Johns, FL 32259

Ship To
Aberdeen CDD Kate Trivelpiece 110 Flower of Scotland Ave. St. Johns, FL 32259 USA

P.O. No.	Rep	Terms
	KC	50%Deposit/Net

Item	Description	Qty	Cost	Total
Method of Delivery	Method of shipping to be determined at time of shipping, whether via dedicated trailer or LTL. Lift gate is subject to availability. If lift gate is requested on the PO and shipping method is determined to be dedicated trailer, driver assist will be provided in place of the lift gate. Property must have access for a 53' trailer and staff on site to unload at time of delivery. If the property does not have access for a 53' you must include this information on your purchase order. The driver must be able to enter and arrive at final destination smoothly and without incident Driver must be able to turn around or have another means of exit. Property is aware that the driver is NOT responsible for any movement of the material, unless driver assist is requested. Even then to the end of the trailer only.		0.00	0.00
Estimated Lead Time	Estimated lead time is 12-14 weeks, not including transit.		0.00	0.00

All first time orders and orders up to \$24,999.99 require a 50% deposit, all orders \$25,000.00 and above require a 75% deposit. The Balance is due once the order ships. Due to Credit Card Processing guidelines, all Credit Card purchases will be processed for the full amount within 7 days of purchase. Orders will not be processed until the credit is approved by Furniture Leisure, Inc. All Custom Orders (made to the customer's specifications) require payment in advance and are non-cancelable and non-returnable. A 25% restocking fee plus all shipping costs are required to return stock merchandise. Customer is responsible for organizing and payment of return freight. Returns must receive a "Return Authorization" from Furniture Leisure, Inc. prior to shipping. All Returns must be received in the original cartons and in new condition.

Subtotal	\$8,288.62
Sales Tax (0.0%)	\$0.00
Order Total	\$8,288.62

The manufacturer of merchandise purchased from Furniture Leisure, Inc. warrants all products. Written warranties are available upon request. Furniture Leisure, Inc. assumes no responsibility to extend, alter, or modify any product warranty.

Furniture Leisure, Inc. will be held harmless against all claims of liability resulting from receiving, installation and use of these products. All Shipments are scheduled ASAP "as soon as possible". All effort will be made to expedite, however the purchaser acknowledges no arrival dates are guaranteed. Customer agrees to pay reasonable collection costs allowed by law and/or attorneys fees incurred in connection with the collection of this transaction. The venue for any litigation with Furniture Leisure, Inc will be Flagler County, FL.

Receiving, Offloading, Assembly, Placement of Furniture, Installation, and Removal of Packing Materials of the merchandise is solely the customer's responsibility and is not included in the above price.

Signature _____ Title _____ Date _____

sales@poolfurnituresupply.com

www.poolfurnituresupply.com



42" Dining Table

Acrylic tables offer a sophisticated look to any outdoor setting and pair well with all aluminum collections. Tables feature a welded aluminum base with an obscured acrylic top within a captured aluminum rim. Acrylic tables are available in your choice of gloss or textured frame finish and are a great solution for both residential and commercial applications.

*This table is available with or without an umbrella hole. To add an umbrella hole add a "U" to the end of the product number.

Specifications

Product Number:	WT4218A
Width:	42
Depth:	42
Height:	28
Weight:	38

 **Furniture Leisure**
Commercial Site Furnishings
1-800-213-2401 | sales@furnitureleisure.com

FurnitureLeisure.com PoolFurnitureSupply.com
PicnicFurniture.com PicnicTableSupplier.com
ParkTables.com UBrace.com

St. Maarten Dining Chair with Arms, Cross Weave

Description

St. Maarten strap furniture has 1" round extrusions and 2" wide virgin vinyl. It is also double wrapped for ensured strength and durability. It is also specially treated for fade resistance and comes in a variety of colors. Making it a perfect choice for both commercial and residential environments.



Specifications

Product Number:	W0350CW
Frame:	Extruded Aluminum
Width (in):	22
Depth (in):	27
Height (in):	35
Seat Height (in):	17
Arm Height (in):	23
Weight (lbs):	12
Stacking:	Yes

NEW

Barcelona Deep Seating



#W3055

Lounge Chair

32.5"W 29"D 26.5"H

Seat: 19"

Arm: 26.5"



#W30155

Armless Lounge Chair

29"W 29"D 26.5"H

Seat: 19"



#W30255R

Right Arm Loveseat

59"W 29"D 26.5"H

Seat: 19"

Arm: 26.5"



#W30255L

Left Arm Loveseat

59"W 29"D 26.5"H

Seat: 19"

Arm: 26.5"



#W30255

Loveseat

61"W 29"D 26.5"H

Seat: 19"

Arm: 26.5"



#W30355

Sofa

88"W 29"D 26.5"H

Seat: 19"

Arm: 26.5"



#W3014

Ottoman

29"W 29"D 19"H

#W30355C

Sofa Corner for Sectional



Deep Cushion Fabric Options

Colors shown may vary by monitor.

Contact us online or speak to us at 1-877-646-6320 to request a color sample.

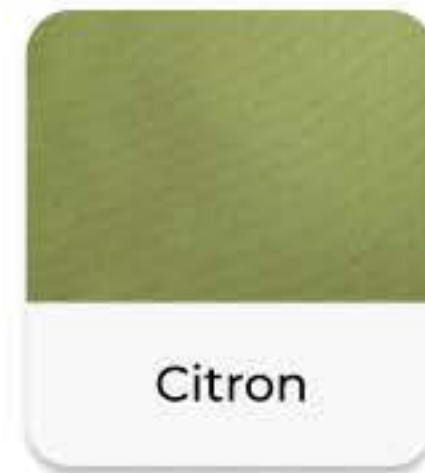
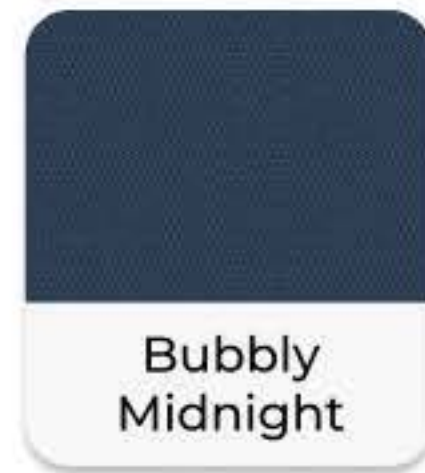
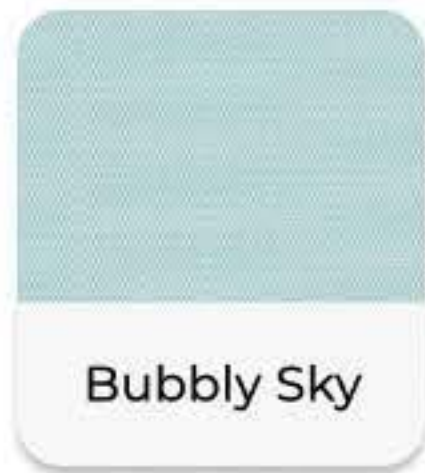
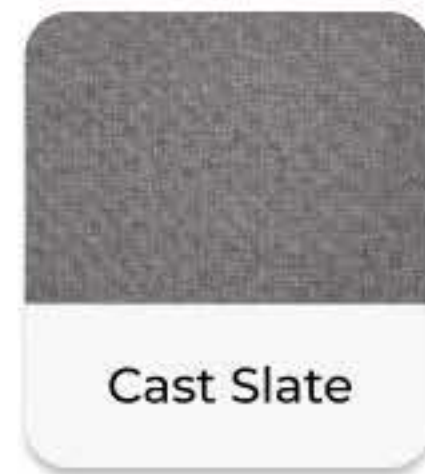
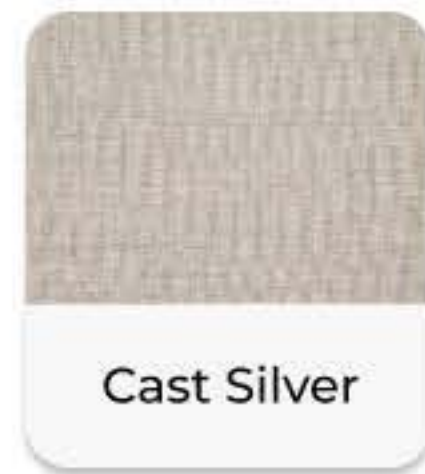

D.

Mobility Plus of Jacksonville

5285 SHAD RD SUITE 207
JACKSONVILLE, FL 32257 US
jacksonville@mobilityplus.com
www.mobilityplusjacksonville.com



Estimate

ADDRESS	SHIP TO	ESTIMATE	1488
Kate Trivelpiece	Kate Trivelpiece	DATE	04/17/2023
Aberdeen CDD	Aberdeen CDD		
110 Flower of Scotland Ave	110 Flower of Scotland Ave		
Saint Johns, FL 32259	Saint Johns, FL 32259		

DATE		DESCRIPTION	QTY	RATE	AMOUNT
04/17/2023	Pool Lift	AquaCreek Scout Excel	2	6,264.00	12,528.00T
04/17/2023	Pool Lift	Paver Anchor	2	467.00	934.00T
04/17/2023	Install-Pool Lift	Cover	2	417.00	834.00T
04/17/2023	Install-Pool Lift	Installation (includes removal & disposal of existing lift)	2	1,850.00	3,700.00T
04/17/2023	Shipping & Freight	Freight	2	563.85	1,127.70T
04/17/2023	Service Labor Warranty	Coincides w Manufacture Warranty	2	0.00	0.00

				SUBTOTAL	19,123.70
				TAX	1,230.40

				TOTAL	\$20,354.10

Accepted By

Accepted Date

THE SCOUT EXCEL



Item# F-SCTXL

The New Scout Excel pool lift is ADA compliant and UL Certified. It was designed to provide greater accessibility solutions with versatility, greater water drafts, and a setback up to 44 inches. Additional features of the new Scout Excel include an adjustable height seat pole, direct drive rotation, and it will accommodate most existing anchors by utilizing adapter sleeves. The optional pull-out leg rest may be used for greater clearance on raised pool and spa applications.

The Scout Excel is ideal for easy and affordable ADA compliance. Like all Aqua Creek lifts, the Scout Excel is constructed from all stainless steel with a durable powder coat finish in your choice of colors; standard white, gray, or tan. Seats and footrests are also available with color options in standard blue, white, gray, and tan.

Purchase the optional solar charging station to help extend the lift of your battery. The Scout Excel comes standard with the best warranty in the industry, a 5 year structural and 5 year prorated electronics warranty.

U.S. Patent Nos.
D507,769S



ACCENT COLORS

Available in a variety of accent and powder coat colors



*Blue seat standard (not a powder coat option)

OPTIONS/ACCESSORIES:

F-808SA	Anchor kit, standard, 1.9" x 6" deep
F-808SA-10	Anchor kit, paver applications, 1.9" ID x 10" deep
F-842SWDA	Anchor kit, wood deck applications
F-77SSA	Anchor kit, semi-recessed, shallow concrete deck
F-450SSC	Cover, standard lockable, blue
F-450SSC-G	Cover, standard lockable, gray
F-450SSC-T	Cover, standard lockable, tan
F-422PLH-2	Headrest
F-LRB	Pull-out leg rest assembly (blue, tan, gray, or white)
F-806SLS	Sling assembly
F-045SCH	Solar charging station
F-814SCTC	Transport cart

FEATURES:

- UL Certified
- 375 lb. (170 kg) weight capacity
- Setback range up to 44"
- 10" water draft
- Adjustable seat pole
- Direct drive rotation
- Flip-up armrests
- All stainless steel construction
- Durable powder coat finish
- Rechargeable battery & wall mount charger
- Five year structural warranty
- Five year pro-rated electronics warranty

PROUDLY SOLD BY:

THE SCOUT EXCEL

PRODUCT SPECIFICATIONS

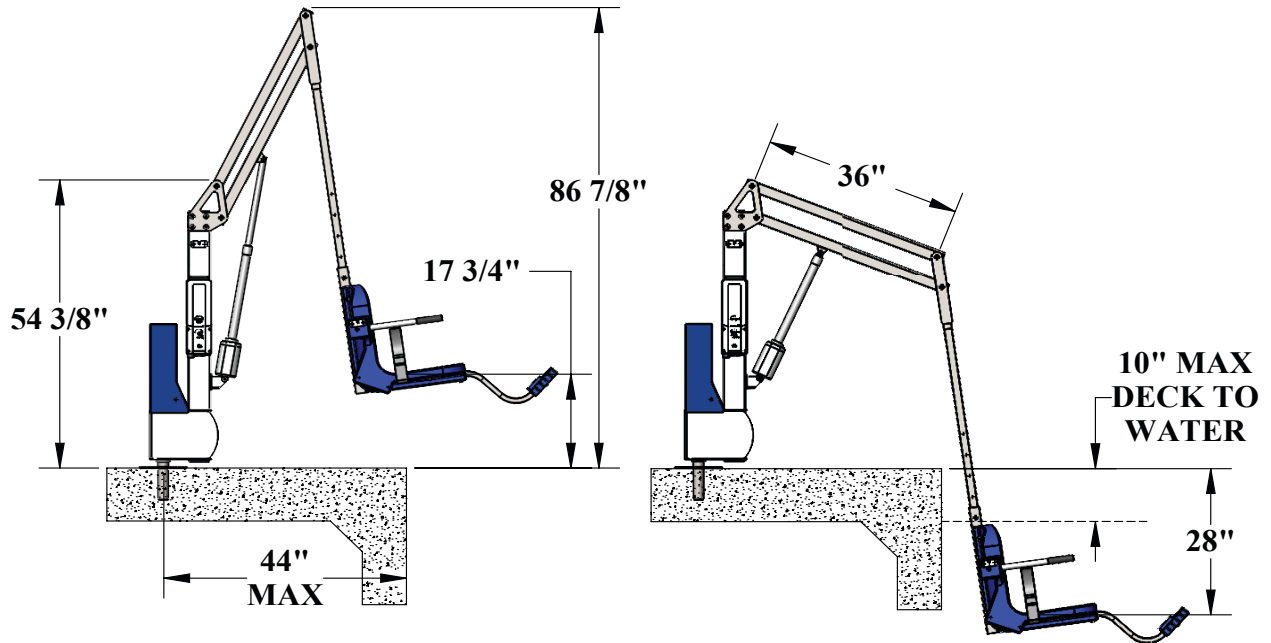

APPLICABLE POOL PROFILES

ROLL OUT

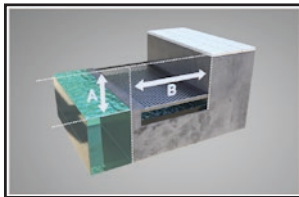

PARTIALLY RECESSED

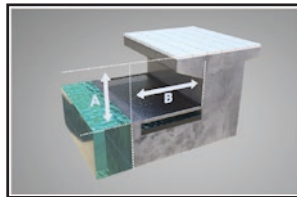

FULLY RECESSED

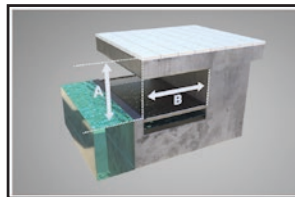

RAISED POOL / SPA

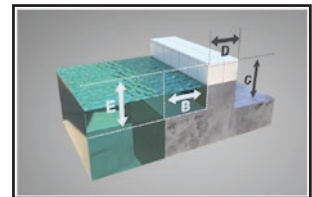

BULL NOSE

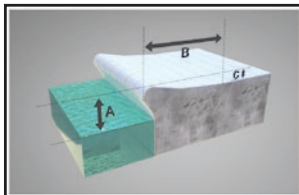

PARTIALLY RECESSED W/CURB

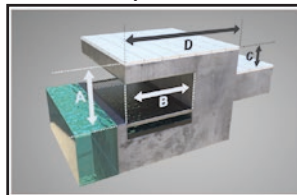

FLUSH W/ POOL DECK

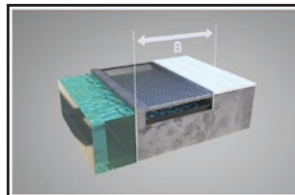

FLORIDA ROLL OUT

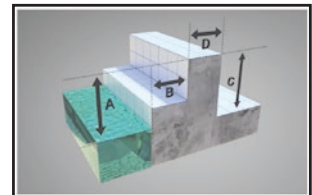

*provide measurements indicated to confirm application or use online pool lift selector

Become a member of our new Dealer and Architect page. Access to CAD blocks, CSI specs and sales materials.



QUOTE

Central Florida Stairlift LLC

2654 Red Fox Run

Chuluota, FL 32766

407-590-4143

chris@centralfloridastairlift.com

Date: 4/18/23

Aberdeen CDD

110 Flower of Scotland Ave

St. Johns, FL 32259

904-217-0925

Quantity		Unit Price	Line Total
2	Aqua Creek Scout Excel ADA Pool Lift	\$6,695.00	\$13,390.00
2	Aqua Creek Scout Excel ADA Anchor System	Included	Included
2	Professional Core Drill Cemented Anchor Installation	Included	Included
	375 lbs. Weight Capacity		
	5 Year Manufacturers Warranty		
	Battery Powered		
	Charger Included		
	In Stock Lift - Immediate Installation (Allow 1-5 business Days)		
	100% Payment Required to be placed on the schedule for installation. We accept all major credit cards or check by mail.		
	NO SALES TAX		
	Multiple Lift Discount	-\$200.00	-\$400.00
		Subtotal	\$ 12,990.00
		Sales Tax @ 0.00%	-
		TOTAL	\$ 12,990.00

THANK YOU FOR YOUR BUSINESS!

Get started using the service invoice

Use this template to create professional looking invoices that are a snap to fill in and are easy for your customers to read.

To get started, in the upper portion, type your company name, address, and phone information in cells C3 through C7 on the template (.xltx) so that it always has this information prepopulated in those cells. Make sure the template is saved somewhere on your computer's templates folder (usually C:\Users*username*\AppData\Roaming\Microsoft\Templates), it will be easily available in the **Templates**. Otherwise, you can click **New from Existing** and then browse to and open your .xltx file. Either way, the first time you open the workbook.

Enter your invoice number and customer ID. The date is automatically filled in for you. Then enter your customer information. Set the tax rate in the cell F39. Enter your company name in Cell C41. Finally, enter all the order transaction information in cells

THE SCOUT EXCEL



Item# F-SCTXL

The New Scout Excel pool lift is ADA compliant and UL Certified. It was designed to provide greater accessibility solutions with versatility, greater water drafts, and a setback up to 44 inches. Additional features of the new Scout Excel include an adjustable height seat pole, direct drive rotation, and it will accommodate most existing anchors by utilizing adapter sleeves. The optional pull-out leg rest may be used for greater clearance on raised pool and spa applications.

The Scout Excel is ideal for easy and affordable ADA compliance. Like all Aqua Creek lifts, the Scout Excel is constructed from all stainless steel with a durable powder coat finish in your choice of colors; standard white, gray, or tan. Seats and footrests are also available with color options in standard blue, white, gray, and tan.

Purchase the optional solar charging station to help extend the lift of your battery. The Scout Excel comes standard with the best warranty in the industry, a 5 year structural and 5 year prorated electronics warranty.

U.S. Patent Nos.
D507,769S



ACCENT COLORS

Available in a variety of accent and powder coat colors



*Blue seat standard (not a powder coat option)

OPTIONS/ACCESSORIES:

F-808SA	Anchor kit, standard, 1.9" x 6" deep
F-808SA-10	Anchor kit, paver applications, 1.9" ID x 10" deep
F-842SWDA	Anchor kit, wood deck applications
F-77SSA	Anchor kit, semi-recessed, shallow concrete deck
F-450SSC	Cover, standard lockable, blue
F-450SSC-G	Cover, standard lockable, gray
F-450SSC-T	Cover, standard lockable, tan
F-422PLH-2	Headrest
F-LRB	Pull-out leg rest assembly (blue, tan, gray, or white)
F-806SLS	Sling assembly
F-045SCH	Solar charging station
F-814SCTC	Transport cart

FEATURES:

- UL Certified
- 375 lb. (170 kg) weight capacity
- Setback range up to 44"
- 10" water draft
- Adjustable seat pole
- Direct drive rotation
- Flip-up armrests
- All stainless steel construction
- Durable powder coat finish
- Rechargeable battery & wall mount charger
- Five year structural warranty
- Five year pro-rated electronics warranty

PROUDLY SOLD BY:

THE SCOUT EXCEL

PRODUCT SPECIFICATIONS

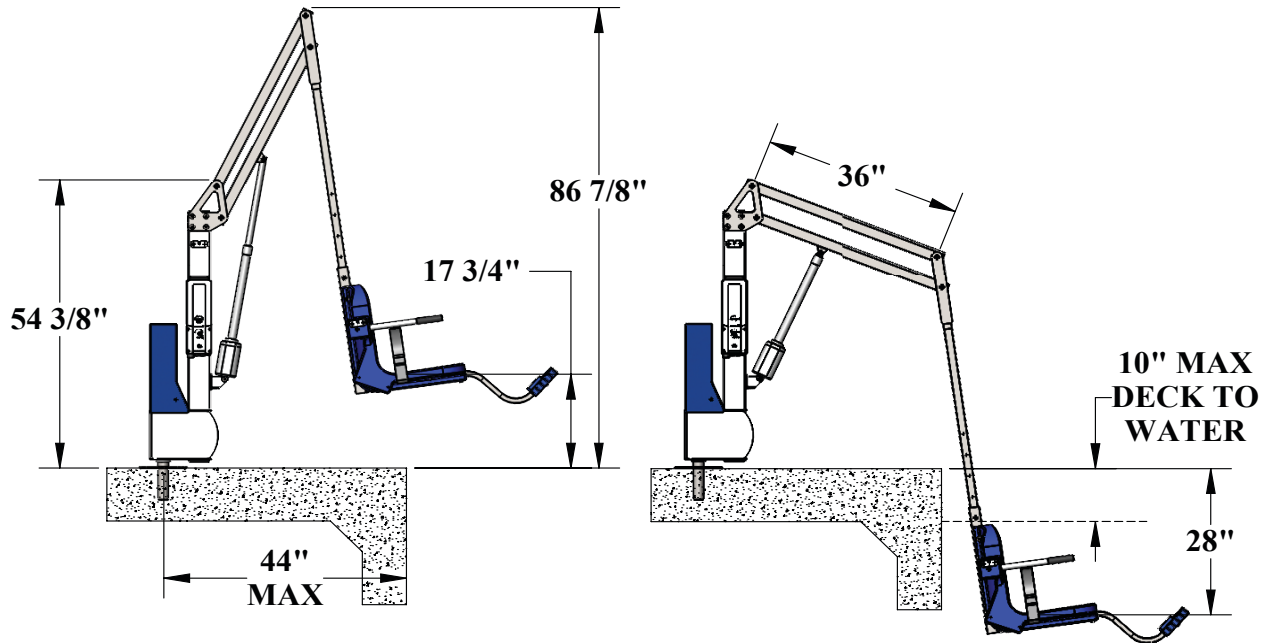

APPLICABLE POOL PROFILES

ROLL OUT

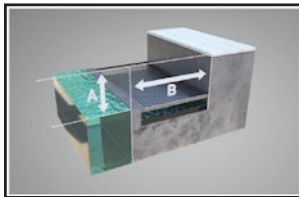

PARTIALLY RECESSED

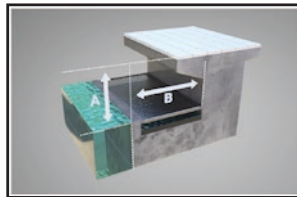

FULLY RECESSED

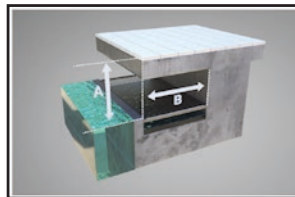

RAISED POOL / SPA

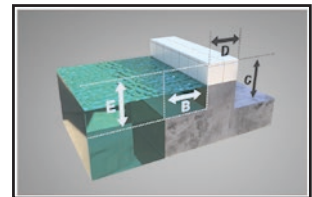

BULL NOSE

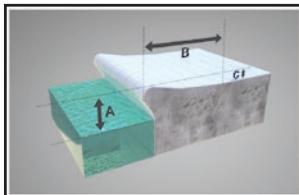

PARTIALLY RECESSED
W/CURB

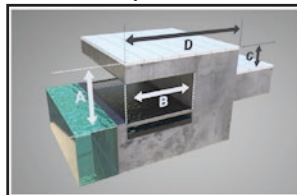

FLUSH W/ POOL DECK

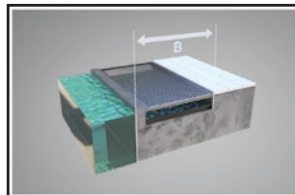

FLORIDA ROLL OUT

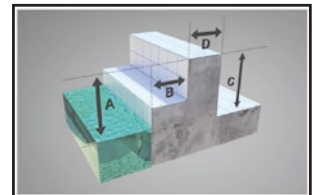

*provide measurements indicated to confirm application or use online pool lift selector

Become a member of our new Dealer and Architect page. Access to CAD blocks, CSI specs and sales materials.

FEATURES

- ◆ UL CERTIFIED ◆ 375 LB. (170 kg.) WEIGHT CAPACITY ◆ SETBACK RANGE 7" TO 44" (18 - 111 cm) ◆ CLEARANCES VARY BY WALL HEIGHT & WIDTH ◆ WATER DRAFT 10" ◆ 360° ROTATION ◆ FLIP UP ARMREST ◆ ALL STAINLESS STEEL CONSTRUCTION ◆ DURABLE POWDER COAT FINISH ◆ RECHARGEABLE BATTERY & WALL MOUNT CHARGER ◆ FIVE YEAR STRUCTURAL WARRANTY ◆ FIVE YEAR PRO-RATED ELECTRONICS WARRANTY

CLICK HERE TO VIEW THIS PRODUCT:
<https://aquacreekproducts.com/scout-excel/>

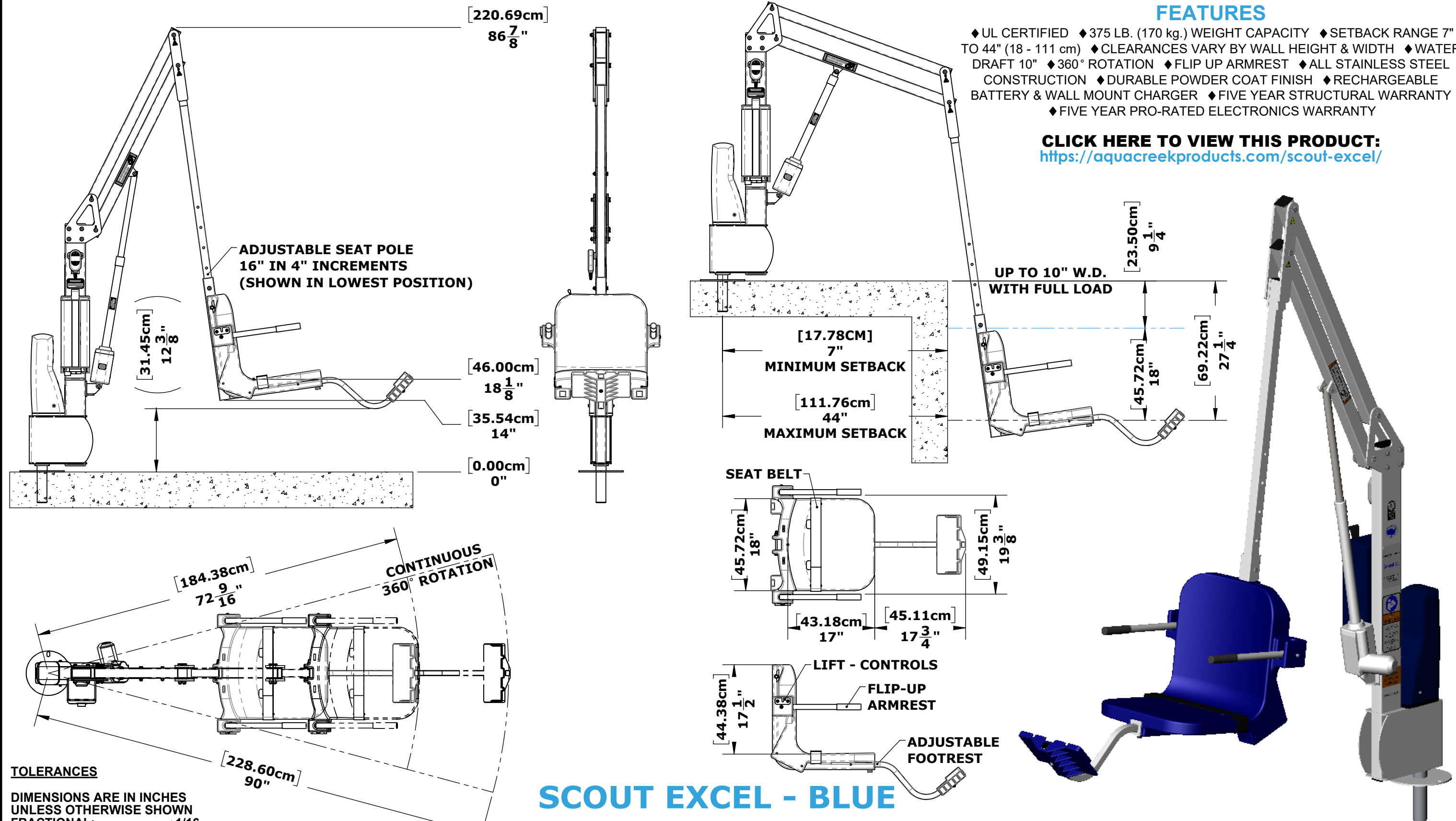

TOLERANCES
DIMENSIONS ARE IN INCHES
UNLESS OTHERWISE SHOWN
FRACTIONAL: ±1/16
ANGULAR: ±1°
TWO PLACE DECIMAL: ±.01
THREE PLACE DECIMAL: .. ±.005

SCOUT EXCEL - BLUE
U.S. PATENT NO. D507,769 S
PART NO. F-SCTXL

MATERIAL: STAINLESS STEEL
FINISH: POWDER COAT - WHITE
APPROX. WEIGHT: 180.94 LBS.

Aqua Creek Products
Leaders in Recreation, Fitness and Ability

9889 GARRYMORE LANE
MISSOULA, MT 59808
(406) 549-0769
FAX (406) 549-2602
www.AquaCreek.com

© 2020 AQUA CREEK PRODUCTS. ALL RIGHTS RESERVED.

PROPRIETY AND CONFIDENTIAL INFORMATION

THIS DRAWING AND ALL INFORMATION CONTAINED HEREIN IS THE SOLE PROPERTY OF AQUA CREEK PRODUCTS LLC. ANY REPRODUCTION IN PART OR AS A WHOLE WITHOUT WRITTEN PERMISSION FROM AQUA CREEK IS PROHIBITED.

*SPECIFICATIONS ARE SUBJECT TO CHANGE WITHOUT NOTICE

REVISIONS			
REV.	DESCRIPTION	DATE	APPROVED
P1	PRODUCTION RELEASE	3/30/2021	J.MAXWELL

PRODUCT NAME: Scout Excel Pool/Spa Access Lift

CSI SECTION: 13 11 46 Swimming Pool Accessories

APPLICATIONS:

- In Ground Pools & Spas with up to **11-inch (27.94cm)** high by **11-inch (27.94cm)** wide curbs.
- On Ground & Partially Recessed Pools & Spas with walls up to **26-inches (66.04cm)** high by **16-inches (40.64cm)** wide when using the Optional pull out leg rest.

SUBMITTALS:

- Alternate make or model lifts will not be considered unless equal to the specified product in every respect. Alternative products must be submitted for approval no less than ten (10) calendar days prior to the bid due date. Submittal data must include complete documentation relating to all the specified features and include all manufacturer's sales literature, specification sheets, installation/operation manuals, engineered drawings and documents that support the strength, service capacity, and the ability to meet the appropriate Federal Regulatory Standards associated with the product.

QUALITY ASSURANCE:

- The product must be a standard product of a company registered with the United States Food and Drug Administration (FDA) as a class 1 medical device manufacturer and that is regularly engaged in the manufacture of commercial grade swimming pool and spa accessibility equipment.
- The product shall be structurally capable of supporting a **375 pound (170.10kg)** load capacity and static load tested to 1.5 times the rated load.
- The product shall be certified to be compliant with UL test standard 60335-2-1000 Standard of Household and Similar Appliances: Particularly Requirements for Electrically Powered Pool Lifts.
- The product shall be tested and confirmed to comply with design standards outlined in the United States ADA Accessibility Standards for Accessible Designs.

SPECIFICATIONS:

- The products main structure shall be constructed of type 304 stainless steel; no dissimilar metallic components shall be allowed. The product shall be finished with a minimum 4-mil thick, UV resistant powder coat finish. All fastening hardware shall be of type 316 stainless steel. Product shall be supplied with a Linak Actuator suitable for medical use, a separate wall mount battery charger, a hand-held controller, and a 24-volt rechargeable battery.
- The chair of the product shall be of a rigid one-piece, polyethylene, molded design. The minimum seat width shall be **18-inches (45.72cm)** and the seat back shall be a minimum height of **17.5-inches (44.45cm)**. The seat shall feature dual flip-up arms and supplied with a 2-inch (5.08cm) wide adjustable safety belt with hook and loop fasteners.
- The seat height of the product will be adjustable from a load height of **18-inches (45.72cm)** to **34-inches (86.36cm)** in **4-inch (10.16cm)** increments to accommodate raised pool and spa walls.
- The product shall be capable of accommodating a deck to water distance (water draft) of up to **10-inches (25.40cm)** and capable of an anchor set back distance of up to **44-inches (111.76cm)**.
- An adjustable and removable footrest that moves with the seat shall be supplied with the product.

WARRANTY:

- Product shall have a minimum 5 year structural and 5 year pro-rated electronic warranty.

LIFT PART NUMBERS:

Item No	Order No	Description
F-SCTXL	INV02394	Scout Excel Lift White Powder Coat w/Blue Seat
F-SCTXL-T	INV02397	Scout Excel Lift White Powder Coat w/Tan Seat
F-SCTXL-G	INV02398	Scout Excel Lift White Powder Coat w/Gray Seat
F-SCTXL-W	INV02399	Scout Excel Lift White Powder Coat w/White Seat
F-SCTXL-C	INV02400	Scout Excel Lift (Specify Seat and Powder Coat Colors)

ANCHORING OPTIONS:

Item No	Order No	Description
F-808SA	INV01494	Scout Excel Lift Anchor for Standard Concrete Decks
F-808SA-10	INV01495	Scout Excel Lift Anchor for Paver Applications
F-842SWDA	INV01504	Scout Excel Lift Anchor for Wood Deck Applications
F-77SSA	INV01489	Scout Excel Lift Semi-Recessed Anchor for 6" Thick Concrete
F-820	INV01497	Scout Excel Lift Anchor Adapter for Existing 2.5-Inch Square Anchors
F-822	INV01498	Scout Excel Lift Anchor Adapter for Existing 2.49-Inch ID Anchors
F-824	INV01499	Scout Excel Lift Anchor Adapter for Existing 2.36-Inch ID Anchors
F-826	INV01500	Scout Excel Lift Anchor Adapter for Existing 2.75-Inch ID Anchors

PRODUCT OPTIONS:

Item No	Order No	Description
F-0904CVR	INV01990	Scout Excel Seat Cover in Blue
F-450SSC	INV00551	Scout Excel Lift Protective Lift Cover in Blue
F-450SSC-B-HE	INV01864	Scout Excel Lift Premium Grade Protective Lift Cover in Blue
F-450SSC-T	INV00553	Scout Excel Lift Protective Lift Cover in Tan
F-450SSC-G	INV00552	Scout Excel Lift Protective Lift Cover in Gray
F-045SCH	INV01692	Scout Excel Lift Solar Charger
F-422PLH-2	INV01455	Scout Excel Lift Adjustable Headrest
F-423CS	INV01457	Scout Excel Lift Chest Strap
F-734RSA	INV01836	Scout Excel Lift Spine Board Assembly
F-MTTC	INV01902	Scout Excel Lift Transport Cart
F-LRB	INV01950	Scout Excel Lift Pull Out Leg Rest Blue
F-LRT	INV01952	Scout Excel Lift Pull Out Leg Rest Tan
F-LRG	INV01954	Scout Excel Lift Pull Out Leg Rest Gray
F-LRW	INV01953	Scout Excel Lift Pull Out Leg Rest White
F-019CA	INV01379	Scout Excel Lift Cycle Attachment

Aqua Creek Products LLC

9889 Garrymore Lane

Missoula, MT 59808

www.aquacreekproducts.com

Tel: 888-687-3552 / 406-549-0769

Fax: 406-541-8958



9889 GARRYMORE LANE
MISSOULA, MT 59808
(406) 549-0769
FAX (406) 549-2602
www.AquaCreek.com

PROPRIETY AND CONFIDENTIAL INFORMATION

THIS DRAWING AND ALL INFORMATION CONTAINED HEREIN IS THE SOLE PROPERTY OF AQUA CREEK PRODUCTS LLC. ANY REPRODUCTION IN PART OR AS A WHOLE WITHOUT WRITTEN PERMISSION FROM AQUA CREEK IS PROHIBITED.

***SPECIFICATIONS ARE SUBJECT TO CHANGE WITHOUT NOTICE**

© 2020 AQUA CREEK PRODUCTS. ALL RIGHTS RESERVED.

FIFTH ORDER OF BUSINESS

E.

Aberdeen CDD GM/LD Agenda
April 25, 2023

GM Update:

➤ Facility Update:

- Still awaiting tables and umbrellas for the pool deck.
- Pool bathroom ceiling, walls, and floor painting nearing completion
- New water filtration pump installed at Fitness Center
- Playground slide replacement recommendation and quote (See attached).

Lifestyle Events Recap:

- Family Movie Night and Glow Egg Hunt well attended (photos attached)
- Spring “Egg”stravaganza event well attended (photos attached)
- 50+ Happy Hour Event was held on 4/14/23.
- Spring Community Yard Sale was held on 4/15/23

Lifestyle Upcoming Events:

- Swim team dry land Practices begin 4/18/23 (Tuesday & Thursdays 5-6pm).
- Swim Team tryouts on 4/27/23 from 4-6pm
- 50+ Potluck Social on 5/12/23
- Last day of school for SJC 5/25/26
- Schools Out Movie Night and Ice Cream Social 5/26/23
- Memorial Day Pool Party on 5/29/23

Movie Night & Glow Egg Hunt



Spring "Egg"stravaganza!

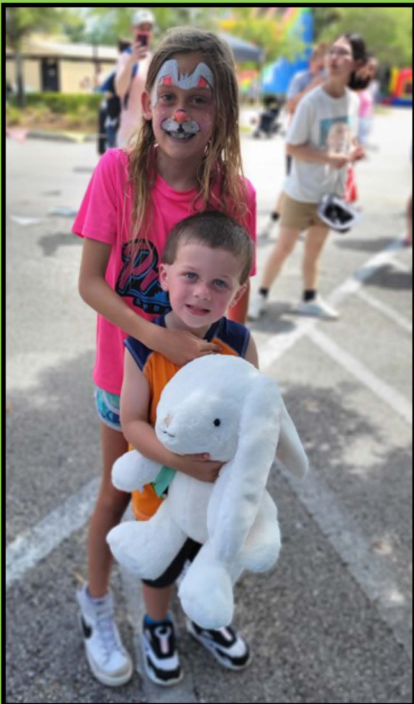



SEVENTH ORDER OF BUSINESS

A.

MINUTES OF MEETING
ABERDEEN
COMMUNITY DEVELOPMENT DISTRICT

The regular meeting of the Board of Supervisors of the Aberdeen Community Development District was held Tuesday, March 28, 2023 at 6:00 p.m. at the Aberdeen Amenity Center, 110 Flower of Scotland Avenue, St. Johns, Florida.

Present and constituting a quorum were:

Lauren Egleston	Chairperson
Angela Andrews	Supervisor
Thomas Marmo	Supervisor
Susie Clarke	Supervisor

Also present were:

Jim Oliver	District Manager
Wes Haber	District Counsel
Kate Trivelpiece	FirstService Residential
Jay Parker	First Service Residential

The following is a summary of the actions taken at the March 28, 2023 meeting.

FIRST ORDER OF BUSINESS

Roll Call

Mr. Oliver called the meeting to order and called the roll.

SECOND ORDER OF BUSINESS

Public Comments

There being none, the next item followed.

THIRD ORDER OF BUSINESS

**Consideration of Renewal Agreement with
Aberdeen Rays Swim Team Regarding Use of
the District's Competition Pool for 2023/2024
Season**

Mr. Haber stated this agreement is in essentially the same form that has been used in years past, it has been a successful relationship, the exhibit has been updated to reflect the dates for this year.

Ms. Andrews asked Lauren are you the head of this or is there someone else?

Ms. Egleston stated the coach and assistant coach who I'm passing this off to couldn't be here today.

Mr. Haber stated as long as there is no pecuniary interest that you have by virtue of your involvement with the team then you are able to vote.

On MOTION by Mr. Marmo seconded by Ms. Clarke With all in favor the agreement with the Aberdeen Rays Swim Team for the 2023/2024 swim season was approved and the schedule will be attached as an exhibit to the agreement.

FOURTH ORDER OF BUSINESS

Update Regarding Future Improvements to Common Area Greenspace and other CDD Owned Facilities and Assets

There being no updates the next item followed.

FIFTH ORDER OF BUSINESS

Consideration of Proposals

Mr. Parker stated I do have two proposals for the fountain and am waiting on a third. One proposal was to fix the boxes and that was \$1,200, which was \$200 over my spending limit. I just received the proposal from Future Horizons for a new box that will be compatible with the fountain.

On MOTION by Ms. Andrews seconded by Mr. Marmo with all in favor the proposal from Future Horizons for a new box that will be compatible with the existing fountain in an amount not to exceed \$4,479 was approved.

SIXTH ORDER OF BUSINESS

Easement Access Request for Fencing (203 Shetland Drive)

Mr. Oliver stated in your agenda packet is the backup from the HOA and yesterday I received an email from the property management company that clarifies that the fence is already along the backyard, the resident wants to put a gate and fence along their side yard. Jay has indicated that this will not affect access to the lake.

On MOTION by Ms. Egleston seconded by Mr. Marmo With all in favor the request for easement access at 203 Shetland Drive was

approved subject to the license agreement prepared by district counsel.

SEVENTH ORDER OF BUSINESS

**Consideration of Resolution 2023-03
Resolution Regarding Records Retention
Policy**

Mr. Haber stated there is a memo and two resolutions attached to the memo. All CDDs are required to have a records retention policy, you can retain records in accordance with federal and state law or retain all records until the board directs otherwise. Most boards opted for the second option and kept all records. The reason you are seeing these resolutions again is because there are two new related matters we wanted to address, the first is called a transitory record, which is record that serves no purpose after a particular date, such as an email that indicates the date of the next meeting and you all respond saying I can make it. After the meeting that transmittal serves no purpose, there is no obligation to retain that record and we want to make it clear as part of the district’s records retention policy that Jim’s office as well as you can delete that transitory record. We wanted to clarify in the policy that as long as the district has electronic copies of records there is no obligation to keep hard copies any longer. Both of those matters have been added to these resolutions. This is supplementing your existing policy to make it easier for your district manager to delete certain records if they are transitory and if we have electronic copies.

Mr. Oliver stated I would rather over retain than under retain and that is option 2.

On MOTION by Ms. Anderson seconded by Ms. Egleston with all in favor Resolution 2023-03, option 2, was approved.

EIGHTH ORDER OF BUSINESS

Staff Reports

A. Attorney

Mr. Haber stated you may see emails from my office about legislative updates, we will continue to send those until the legislative sessions ends. There are bills that may or may not affect CDDs, but you don’t know what will pass and what won’t. Once we know we will let you know.

B. Engineer

There being none, the next item followed.

C. Manager

Mr. Oliver stated we will bring a preliminary budget to the April meeting and bring the proposed budget to the May meeting and have your budget hearing for adoption in August.

D. Operation Manager

Mr. Parker reviewed the items outlined in the monthly memorandum, and stated we have been changing the water fountain filters every month at the cost of \$60 and I had a plumber come out and he said we can fix that by putting up a sediment filter and that is \$1,300.

On MOTION by Ms. Egleston seconded by Ms. Clarke with all in favor the purchase of a sediment filter for the water fountain -in the amount of \$1,300 was approved.

E. Amenity Center Manager - Report

Ms. Trivelpiece reviewed the amenity center activities and maintenance items, which were outlined on the monthly memorandum, that was included as part of the agenda package.

NINTH ORDER OF BUSINESS

Supervisors Requests and Public Comments

There being none, the next item followed.

TENTH ORDER OF BUSINESS

Approval of Consent Agenda

- A. Approval of the Minutes of the February 28, 2023 Meeting**
- B. Balance Sheet as of February 28, 2023 and Statement of Revenues and Expenses for the Period Ending February 28, 2023**
- C. Assessment Receipt Schedule**
- D. Approval of Check Register**

On MOTION by Mr. Marmo seconded by Ms. Egleston with all in favor the consent agenda items were approved.

TENTH ORDER OF BUSINESS

Next Scheduled Meeting – 04/25/23 @ 4:00 p.m. @ Aberdeen Amenity Center

Mr. Oliver stated the next meeting is scheduled for April 25, 2023 at 4:00 p.m. in the same location.

On MOTION by Ms. Andrews seconded by Ms. Egleston with all in favor the meeting adjourned at 6:52 p.m.

Secretary/Assistant Secretary

Chairman/Vice Chairman

B.

Aberdeen

Community Development District

Unaudited Financial Reporting

March 31, 2023

Aberdeen
Community Development District
Combined Balance Sheet

March 31, 2023

	<u>Governmental Fund Types</u>				Totals (Memorandum Only)
	<u>General</u>	<u>Debt Service</u>	<u>Capital Reserve</u>	<u>Capital Projects</u>	
Assets:					
Cash	\$727,868	---	\$455,458	---	\$1,183,326
Investments:					
Operations					
Custody Account	\$55,089	---	---	---	\$55,089
State Board of Administration - General Fund	\$50,948	---	---	---	\$50,948
State Board of Administration - Capital Reserve	---	---	\$164,242	---	\$164,242
State Board of Administration - Renewal & Rplcmt	---	---	\$108,394	---	\$108,394
Series 2005/2020A					
Reserve A1	---	\$378,625	---	---	\$378,625
Interest A1	---	\$5,419	---	---	\$5,419
Prepayment A1	---	\$4,430	---	---	\$4,430
Revenue	---	\$1,923,149	---	---	\$1,923,149
Reserve A2	---	\$218,250	---	---	\$218,250
Interest A2	---	\$3,124	---	---	\$3,124
Prepayment A2	---	\$2,669	---	---	\$2,669
General Redemption	---	\$34,068	---	---	\$34,068
Series 2018					
Reserve	---	\$67,138	---	---	\$67,138
Revenue	---	\$136,361	---	---	\$136,361
Prepayment	---	\$127	---	---	\$127
Redemption	---	\$1,297	---	---	\$1,297
Construction	---	---	---	\$48,259	\$48,259
Due from Other	\$140	---	---	---	\$140
Prepaid Expenses	\$1,948	---	---	---	\$1,948
Total Assets	\$835,992	\$2,774,658	\$728,094	\$48,259	\$4,387,002
Liabilities:					
Accounts Payable	\$31,832	---	\$12,745	---	\$44,577
Fund Balances:					
Restricted for Debt Service	---	\$2,774,658	---	---	\$2,774,658
Restricted for Capital Projects	---	---	---	\$48,259	\$48,259
Nonspendable	\$1,948	---	---	---	\$1,948
Assigned	\$125,000	---	---	---	\$125,000
Unassigned	\$677,212	---	\$715,349	---	\$1,392,560
Total Liabilities and Fund Equity	\$835,992	\$2,774,658	\$728,094	\$48,259	\$4,387,002

Aberdeen
Community Development District
General Fund

Statement of Revenues & Expenditures
for the period ending
March 31, 2023

	ADOPTED BUDGET	PRORATED BUDGET Thru 03/31/23	ACTUAL Thru 03/31/23	VARIANCE
REVENUES:				
Assessments - Tax Roll	\$1,138,335	\$1,118,195	\$1,118,195	\$0
Interest	\$200	\$200	\$3,197	\$2,997
Amenities Revenue/Misc	\$25,000	\$12,500	\$10,458	(\$2,042)
TOTAL REVENUES	\$1,163,535	\$1,130,895	\$1,131,850	\$956

EXPENDITURES:

Administrative

Supervisor Fees	\$12,000	\$6,000	\$5,000	\$1,000
FICA Expense	\$918	\$459	\$383	\$77
Assessment Administration	\$5,000	\$5,000	\$5,000	\$0
Engineering Fees	\$7,000	\$3,500	\$2,117	\$1,383
Arbitrage	\$1,200	\$600	\$0	\$600
Dissemination Agent	\$7,800	\$3,900	\$3,500	\$400
Impact Fee Administration	\$10,000	\$5,000	\$0	\$5,000
Attorney Fees	\$37,000	\$18,500	\$6,302	\$12,198
Annual Audit	\$3,650	\$1,825	\$0	\$1,825
Trustee Fees	\$14,500	\$6,853	\$6,853	\$0
Management Fees	\$52,796	\$26,398	\$26,398	\$0
Information Technology	\$1,800	\$900	\$900	\$0
Travel and Per Diem	\$300	\$150	\$0	\$150
Telephone	\$700	\$350	\$208	\$142
Postage	\$2,000	\$1,000	\$438	\$562
Printing and Binding	\$2,000	\$1,000	\$357	\$643
Insurance	\$12,408	\$12,408	\$11,116	\$1,292
Legal Advertising	\$2,000	\$1,000	\$272	\$728
Other Current Charges	\$1,000	\$500	\$10	\$490
Office Supplies	\$250	\$125	\$203	(\$78)
Dues, Licenses & Subscriptions	\$175	\$175	\$175	\$0
TOTAL ADMINISTRATIVE EXPENDITURES	\$174,497	\$95,643	\$69,232	\$26,411

Amenity Center

Insurance	\$41,825	\$41,825	\$38,674	\$3,151
Repairs & Replacements	\$45,000	\$22,500	\$29,911	(\$7,411)
Special Events	\$18,500	\$18,500	\$20,420	(\$1,920)
Staff Uniforms	\$1,500	\$750	\$0	\$750
Recreational Supplies	\$1,800	\$900	\$0	\$900
Recreational Passes	\$1,600	\$800	\$696	\$104
Other Current Charges	\$1,000	\$500	\$0	\$500
Permit Fees	\$2,200	\$2,200	\$3,040	(\$840)
Office Supplies	\$3,150	\$1,575	\$1,467	\$108
Credit Card Machine Fees	\$450	\$225	\$349	(\$124)
Pest Control	\$3,000	\$1,500	\$1,192	\$308
Utilities				
Water & Sewer	\$20,000	\$10,000	\$6,721	\$3,279
Electric	\$40,000	\$20,000	\$20,849	(\$849)
Cable/Internet/Phone	\$12,500	\$6,250	\$7,557	(\$1,307)

Aberdeen

Community Development District General Fund

Statement of Revenues & Expenditures
for the period ending
March 31, 2023

	ADOPTED BUDGET	PRORATED BUDGET Thru 03/31/23	ACTUAL Thru 03/31/23	VARIANCE
<u>Management Contracts</u>				
Field Operations Management - FirstService	\$72,440	\$36,220	\$41,495	(\$5,275)
Pool Attendants/Lifeguards - Elite LifeGuard	\$50,000	\$25,000	\$7,312	\$17,688
Facility Management - FirstService	\$99,441	\$49,721	\$53,647	(\$3,927)
Pool Maintenance/Supplies - FirstService	\$28,210	\$14,105	\$11,830	\$2,275
Janitorial Services - FirstService	\$54,240	\$27,120	\$17,079	\$10,041
General Facility Maintenance - FirstService	\$40,560	\$20,280	\$28,551	(\$8,271)
Resident Services Coordinator- FirstService	\$49,040	\$24,520	\$27,510	(\$2,990)
Management Fee - FirstService	\$12,900	\$6,450	\$6,450	\$0
Pool Chemicals - Poolsure	\$30,000	\$15,000	\$14,664	\$336
Refuse Service	\$12,000	\$6,000	\$6,178	(\$178)
Security	\$17,800	\$8,900	\$10,121	(\$1,221)
Website	\$1,800	\$900	\$900	\$0
Holiday Decorations	\$12,000	\$8,827	\$8,827	\$0
Subscriptions	\$2,988	\$1,494	\$1,494	\$0
TOTAL AMENITY CENTER EXPENDITURES	\$675,944	\$372,061	\$366,934	\$5,128
<u>Grounds Maintenance</u>				
Electric	\$11,000	\$5,500	\$6,017	(\$517)
Streetlighting	\$33,000	\$16,500	\$17,684	(\$1,184)
Lake Maintenance	\$33,000	\$16,500	\$16,417	\$83
Landscape Maintenance	\$258,568	\$129,284	\$129,284	(\$0)
Common Area Maintenance	\$30,525	\$15,263	\$5,150	\$10,113
Reuse Water	\$55,000	\$27,500	\$15,123	\$12,377
Miscellaneous	\$7,000	\$3,500	\$541	\$2,959
Irrigation Repairs	\$10,000	\$5,000	\$500	\$4,500
TOTAL GROUNDS MAINT. EXPENDITURES	\$438,093	\$219,047	\$190,717	\$28,329
TOTAL EXPENDITURES	\$1,288,535	\$686,751	\$626,883	\$59,868
EXCESS REVENUES/(EXPENSES)	(\$125,000)		\$504,968	
NET CHANGE IN FUND BALANCE	(\$125,000)		\$504,968	
Fund Balance - Beginning	\$125,000		\$299,192	
Fund Balance - Ending	<u>\$0</u>		<u>\$804,160</u>	

Aberdeen Community Development District

General Fund

Statement of Revenues & Expenditures

Fiscal Year 2023

	Oct	Nov	Dec	Jan	Feb	Mar	Apr	May	Jun	Jul	Aug	Sept	Total
Assessment - Tax Roll	\$0	\$64,746	\$261,183	\$744,254	\$43,545	\$4,467	\$0	\$0	\$0	\$0	\$0	\$0	\$1,118,195
Interest	\$116	\$145	\$127	\$347	\$493	\$1,970	\$0	\$0	\$0	\$0	\$0	\$0	\$3,197
Amenities Revenue	\$2,079	\$2,469	\$100	\$2,126	\$1,394	\$2,290	\$0	\$0	\$0	\$0	\$0	\$0	\$10,458
TOTAL REVENUES	\$2,194	\$67,360	\$261,410	\$746,727	\$45,432	\$8,726	\$0	\$0	\$0	\$0	\$0	\$0	\$1,131,850

EXPENDITURES:

Administrative

Supervisor Fees	\$1,200	\$600	\$200	\$1,200	\$0	\$1,800	\$0	\$0	\$0	\$0	\$0	\$0	\$5,000
FICA Expense	\$92	\$46	\$15	\$92	\$0	\$138	\$0	\$0	\$0	\$0	\$0	\$0	\$383
Assessment Administration	\$5,000	\$0	\$0	\$0	\$0	\$0	\$0	\$0	\$0	\$0	\$0	\$0	\$5,000
Engineering Fees	\$1,795	\$0	\$0	\$0	\$323	\$0	\$0	\$0	\$0	\$0	\$0	\$0	\$2,117
Arbitrage	\$0	\$0	\$0	\$0	\$0	\$0	\$0	\$0	\$0	\$0	\$0	\$0	\$0
Dissemination Agent	\$583	\$583	\$583	\$583	\$583	\$583	\$0	\$0	\$0	\$0	\$0	\$0	\$3,500
Impact Fee Administration	\$0	\$0	\$0	\$0	\$0	\$0	\$0	\$0	\$0	\$0	\$0	\$0	\$0
Attorney Fees	\$2,738	\$1,500	\$348	\$1,716	\$0	\$0	\$0	\$0	\$0	\$0	\$0	\$0	\$6,302
Annual Audit	\$0	\$0	\$0	\$0	\$0	\$0	\$0	\$0	\$0	\$0	\$0	\$0	\$0
Trustee Fees	\$3,438	\$3,416	\$0	\$0	\$0	\$0	\$0	\$0	\$0	\$0	\$0	\$0	\$6,853
Management Fees	\$4,400	\$4,400	\$4,400	\$4,400	\$4,400	\$4,400	\$0	\$0	\$0	\$0	\$0	\$0	\$26,398
Information Technology	\$150	\$150	\$150	\$150	\$150	\$150	\$0	\$0	\$0	\$0	\$0	\$0	\$900
Travel and Per Diem	\$0	\$0	\$0	\$0	\$0	\$0	\$0	\$0	\$0	\$0	\$0	\$0	\$0
Telephone	\$79	\$34	\$33	\$19	\$8	\$34	\$0	\$0	\$0	\$0	\$0	\$0	\$208
Postage	\$16	\$16	\$336	\$45	\$16	\$9	\$0	\$0	\$0	\$0	\$0	\$0	\$438
Printing and Binding	\$113	\$96	\$57	\$17	\$43	\$31	\$0	\$0	\$0	\$0	\$0	\$0	\$357
Insurance	\$11,116	\$0	\$0	\$0	\$0	\$0	\$0	\$0	\$0	\$0	\$0	\$0	\$11,116
Legal Advertising	\$68	\$68	\$0	\$68	\$68	\$0	\$0	\$0	\$0	\$0	\$0	\$0	\$272
Other Current Charges	\$0	\$0	\$0	\$10	\$0	\$0	\$0	\$0	\$0	\$0	\$0	\$0	\$10
Office Supplies	\$137	\$63	\$1	\$1	\$1	\$0	\$0	\$0	\$0	\$0	\$0	\$0	\$203
Dues, Licenses & Subscriptions	\$175	\$0	\$0	\$0	\$0	\$0	\$0	\$0	\$0	\$0	\$0	\$0	\$175
TOTAL ADMINISTRATIVE EXPENDITURES	\$31,098	\$10,970	\$6,124	\$8,301	\$5,592	\$7,146	\$0	\$0	\$0	\$0	\$0	\$0	\$69,232

Amenity Center

Insurance	\$38,674	\$0	\$0	\$0	\$0	\$0	\$0	\$0	\$0	\$0	\$0	\$0	\$38,674
Repairs & Replacements	\$4,719	\$5,095	\$5,352	\$2,701	\$1,331	\$10,713	\$0	\$0	\$0	\$0	\$0	\$0	\$29,911
Special Events	\$5,447	\$4,170	\$1,909	\$3,165	\$2,896	\$2,833	\$0	\$0	\$0	\$0	\$0	\$0	\$20,420
Staff Uniforms	\$0	\$0	\$0	\$0	\$0	\$0	\$0	\$0	\$0	\$0	\$0	\$0	\$0
Recreational Supplies	\$0	\$0	\$0	\$0	\$0	\$0	\$0	\$0	\$0	\$0	\$0	\$0	\$0
Recreational Passes	\$0	\$0	\$696	\$0	\$0	\$0	\$0	\$0	\$0	\$0	\$0	\$0	\$696
Other Current Charges	\$0	\$0	\$0	\$0	\$0	\$0	\$0	\$0	\$0	\$0	\$0	\$0	\$0
Permit Fees	\$0	\$0	\$3,040	\$0	\$0	\$0	\$0	\$0	\$0	\$0	\$0	\$0	\$3,040
Office Supplies	\$15	\$765	\$84	\$143	\$394	\$67	\$0	\$0	\$0	\$0	\$0	\$0	\$1,467
Credit Card Machine Fees	\$66	\$46	\$80	\$28	\$78	\$51	\$0	\$0	\$0	\$0	\$0	\$0	\$349
Pest Control	\$189	\$189	\$189	\$208	\$208	\$208	\$0	\$0	\$0	\$0	\$0	\$0	\$1,192
Utilities													
Water & Sewer	\$710	\$1,419	\$1,319	\$1,260	\$1,001	\$1,012	\$0	\$0	\$0	\$0	\$0	\$0	\$6,721
Electric	\$4,785	\$3,578	\$2,656	\$2,791	\$3,766	\$3,273	\$0	\$0	\$0	\$0	\$0	\$0	\$20,849
Cable/Internet/Phone	\$1,166	\$1,219	\$1,248	\$1,277	\$1,308	\$1,339	\$0	\$0	\$0	\$0	\$0	\$0	\$7,557

Management Contracts

Aberdeen
Community Development District
Debt Service Fund-Series 2018
Statement of Revenues & Expenditures
For the Period Ending
March 31, 2023

	APPROVED BUDGET	PRORATED Thru 03/31/23	ACTUAL Thru 03/31/23	VARIANCE
Revenues:				
Special Assessments - Tax Roll	\$134,960	\$132,576	\$132,576	\$0
Interest Income	\$200	\$200	\$1,993	\$1,793
Total Revenues	\$135,160	\$132,776	\$134,569	\$1,793
Expenditures				
Interest 11/1	\$48,100	\$48,100	\$48,100	\$0
Interest 5/1	\$35,000	\$0	\$0	\$0
Principal 5/1	\$35,000	\$0	\$0	\$0
Total Expenditures	\$166,200	\$48,100	\$48,100	\$0
Excess Revenues (Expenditures)	(\$31,040)	\$84,676	\$86,469	\$1,793
NET CHANGE IN FUND BALANCE			\$86,469	
Fund Balance - Beginning	\$49,605		\$118,454	
Fund Balance - Ending	\$18,565		\$204,923	

Reserve	\$67,138
Revenue	\$136,361
Prepayment	\$127
Redemption	\$1,297
Assessment Receivable	\$0
	\$204,923

Aberdeen
Community Development District
Debt Service Fund-Series 2005 and Series 2020A1 and A2
Statement of Revenues & Expenditures
For the Period Ending
March 31, 2023

	ADOPTED BUDGET	PRORATED Thru 03/31/23	ACTUAL Thru 03/31/23	VARIANCE
Revenues:				
Special Assessments - Tax Roll	\$1,947,438	\$1,913,038	\$1,913,038	\$0
Interest Income	\$1,000	\$1,000	\$21,627	\$20,627
Total Revenues	\$1,948,438	\$1,914,038	\$1,934,665.82	\$20,627
Expenditures				
2020 A1				
Interest 11/1	\$317,419	\$317,419	\$317,419	\$0
Interest 5/1	\$317,419	\$0	\$0	\$0
Principal 5/1	\$900,000	\$0	\$0	\$0
2020 A2				
Interest 11/1	\$99,481	\$99,481	\$99,481	\$0
Interest 5/1	\$99,481	\$0	\$0	\$0
Principal 5/1	\$225,000	\$0	\$0	\$0
Total Expenditures	\$1,958,800	\$416,900	\$416,900	\$0
Fund Balance - Beginning	\$433,443		\$1,051,969	
Fund Balance - Ending	\$423,081		\$2,569,734	
			Reserve A1	\$378,625
			Reserve A2	\$218,250
			Interest A1	\$5,419
			Interest A2	\$3,124
			Revenue	\$1,923,149
			Prepayment A1	\$4,430
			Prepayment A2	\$2,669
			General Redemption	\$34,068
			Assessment Receivable	\$0
				<u><u>\$2,569,734</u></u>

Aberdeen

Community Development District

Capital Reserve Fund

Statement of Revenues & Expenditures

For the Period Ending

March 31, 2023

	ADOPTED BUDGET	PRORATED Thru 03/31/23	ACTUAL Thru 03/31/23	VARIANCE
Revenues:				
Insurance Proceeds	\$0	\$0	\$785	\$785
Impact Fees	\$0	\$0	\$10,153	\$10,153
Interest	\$3,000	\$3,000	\$14,187	\$11,187
Total Revenues	\$3,000	\$3,000	\$25,125	\$22,125
Expenditures				
Capital Outlay	\$150,000	\$75,000	\$25,490	\$49,510
Repair and Replacements	\$100,000	\$50,000	\$52,235	(\$2,235)
Total Expenditures	\$250,000	\$125,000	\$77,725	\$47,275
Excess Revenues (Expenditures)	(\$247,000)		(\$52,600)	
Fund Balance - Beginning	\$778,569		\$767,948	
Fund Balance - Ending	\$531,569		\$715,349	

Aberdeen
Community Development District
Capital Projects Fund
Statement of Revenues & Expenditures
For the Period Ending
March 31, 2023

	SERIES 2018
<u>REVENUES:</u>	
Interest	\$758
Total Revenues	\$758
<u>EXPENDITURES:</u>	
Capital Outlay	\$0
Cost of Issuance	\$0
Total Expenditures	\$0
<u>OTHER SOURCES/(USES)</u>	
Interfund Transfer In/(Out)	\$0
Total Other Sources/(Uses)	\$0
Excess Revenues (Expenditures)	\$758
Fund Balance - Beginning	\$47,501
Fund Balance - Ending	\$48,259

Aberdeen
Community Development District
Long Term Debt Report

Series 2018 Special Assessment Bonds	
Interest Rate:	4%-5.1%
Maturity Date:	5/1/2049
Reserve Fund Definition:	50% of MADS
Reserve Fund Requirement:	\$67,138
Reserve Fund Balance:	\$67,138
Bonds outstanding - 11/01/2018	\$2,065,000
Less: February 3, 2020 (Prepayment)	(\$5,000)
Less: May 1, 2020 (Mandatory)	(\$30,000)
Less: August 3, 2020 (Prepayment)	(\$5,000)
Less: November 1, 2020 (Prepayment)	(\$5,000)
Less: May 1, 2021 (Mandatory)	(\$35,000)
Less: May 1, 2021 (Prepayment)	(\$5,000)
Less: May 1, 2022 (Mandatory)	(\$35,000)
Less: May 1, 2022 (Prepayment)	(\$5,000)
Current Bonds Outstanding	\$1,940,000

Series 2020-A1 Special Assessment Revenue Refunding Bonds	
Interest Rate:	2.625-5.0%
Maturity Date:	11/1/2036
Reserve Fund Definition:	25% of DSRF
Reserve Fund Requirement:	\$378,625
Reserve Fund Balance:	\$378,625
Bonds outstanding - 5/20/2020	\$18,485,000
Less: May 1, 2021 (Mandatory)	(\$815,000)
Less: November 1, 2021 (Prepayment)	(\$15,000)
Less: May 1, 2022 (Mandatory)	(\$855,000)
Less: May 1, 2022 (Prepayment)	(\$10,000)
Current Bonds Outstanding	\$16,790,000

Series 2020 A-2 Special Assessment Revenue Refunding Bonds	
Interest Rate:	4.0-4.75%
Maturity Date:	5/1/2049
Reserve Fund Definition:	50% of DSRF
Reserve Fund Requirement:	\$218,250
Reserve Fund Balance:	\$218,250
Bonds outstanding - 5/20/2020	\$4,890,000
Less: May 1, 2021 (Mandatory)	(\$215,000)
Less: May 1, 2022 (Mandatory)	(\$225,000)
Less: May 1, 2022 (Prepayment)	(\$150,000)
Current Bonds Outstanding	\$4,300,000

C.

ABERDEEN COMMUNITY DEVELOPMENT DISTRICT
Fiscal Year 2023 Summary of Assessment Receipts

ASSESSED	# UNITS ASSESSED	SERIES 2020 DEBT ASMT	SERIES 2018 DEBT ASMT	FY23 O&M ASMT	TOTAL ASSESSED
NET ASSESSMENTS TAX ROLL	50,936	1,947,437.99	134,960.07	1,138,301.72	3,220,699.78
TAX ROLL RECEIVED		1,913,038.45	132,576.15	1,118,194.77	3,163,809.37
BALANCE DUE		34,399.54	2,383.92	20,106.95	56,890.41

Units include 49,000 square feet of Commercial

SUMMARY OF TAX ROLL RECEIPTS					
ST JOHNS COUNTY DISTRIBUTION	DATE RECEIVED	AMOUNT RECEIVED	SERIES 2020 DEBT RECEIPTS	SERIES 2018 DEBT RECEIPTS	O&M RECEIPTS
1	11/2/2022	10,254.76	6,200.67	429.72	3,624.37
2	11/17/2022	87,494.29	52,904.56	3,666.36	30,923.37
3	11/28/2022	85,441.91	51,663.56	3,580.35	30,198.00
4	12/12/2022	298,327.09	180,387.35	12,501.09	105,438.65
5	12/15/2022	440,661.38	266,451.63	18,465.46	155,744.29
6	1/20/2023	2,101,476.91	1,270,685.33	88,060.20	742,731.38
INTEREST	2/1/2023	4,308.30	2,605.07	180.53	1,522.70
7	2/21/2023	123,206.90	74,498.65	5,162.86	43,545.39
8	3/30/2023	12,637.83	7,641.63	529.58	4,466.62
			-	-	-
			-	-	-
			-	-	-
			-	-	-
			-	-	-
			-	-	-
			-	-	-
			-	-	-
TOTAL TAX ROLL RECEIPTS		3,163,809.37	1,913,038.45	132,576.15	1,118,194.77
PERCENT COLLECTED TAX ROLL		98.23%	98.23%	98.23%	98.23%

D.

Aberdeen

Community Development District

Check Run Summary

3/1/2023-3/31/2023

	Check Date	Check No.		Amount
--	------------	-----------	--	--------

General Fund - Wells Fargo

Payroll	3/2/23	50896-50900	\$	923.50
	3/29/23	50901-50904	\$	738.80

Total				\$ 1,662.30
--------------	--	--	--	--------------------

General Fund - Wells Fargo

Accounts Payable	3/9/23	4586-4593	\$	56,744.77
	3/23/23	4594-4600	\$	7,287.20
	3/31/23	4601-4604	\$	57,995.91

\$ 122,027.88

Capital Reserve Fund - Wells Fargo

Accounts Payable	3/9/23	142-143	\$	5,036.15
------------------	--------	---------	----	----------

\$ 5,036.15

Total				\$ 127,064.03
--------------	--	--	--	----------------------

Autopayments - Wells Fargo

3/2/23	Hi-Tech System		\$	250.00
3/2/23	GFL Environmental		\$	1,073.82
3/8/23	Comcast		\$	498.59
3/17/23	Comcast		\$	648.96
3/20/23	JEA Utilities		\$	10,462.37
3/27/23	Comcast		\$	191.30
3/27/23	Wellbeats		\$	249.00
3/28/23	Wells Fargo Credit Card		\$	7,391.01
3/30/23	GFL Environmental		\$	1,073.82

Total				\$ 21,838.87
--------------	--	--	--	---------------------

*Autopayment invoices and Wells Fargo Credit Card invoices will be available upon request.

Check Approval Form

Date: March 2, 2023

District: Aberdeen CDD

Fund Code: 1

Beginning Check #: 50896

Ending Check #: 50900

Total Amount of Checks: \$ 923.50 New Balance

Balance in Account***: \$ 939,944.13 \$ 939,020.63

Recent Deposits: _____

Prepared by: Daniel Laughlin

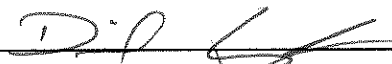
Signature:  _____

Approved by: Jim Oliver

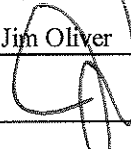
Signature:  _____

CHECK #	EMP #	EMPLOYEE NAME	CHECK AMOUNT	CHECK DATE
50896	12	ANGELA MARIE ANDREWS	184.70	3/02/2023
50897	17	HARRIET S CLARKE	184.70	3/02/2023
50898	15	LAUREN Q EGLESTON	184.70	3/02/2023
50899	18	PAUL R FOGEL	184.70	3/02/2023
50900	16	THOMAS G MARMO	184.70	3/02/2023
TOTAL FOR REGISTER			923.50	

ABER ABERDEEN

DLAUGHLIN

ATTENDANCE SHEET

District: Aberdeen

Meeting Date: 02.28.23

	Supervisor	In Attendance	Fees
1.	Lauren Eggleston <i>Chairperson</i>	<input checked="" type="checkbox"/>	\$200
2.	Susie Clarke <i>Assistant Secretary</i>	<input checked="" type="checkbox"/>	\$200
3.	Thomas Marmo <i>Assistant Secretary</i>	<input checked="" type="checkbox"/>	\$200
4.	Paul Fogel <i>Vice Chairman</i>	<input checked="" type="checkbox"/>	\$200
5.	Angela Andrews <i>Assistant Secretary</i>	<input checked="" type="checkbox"/>	\$200

District Manager:

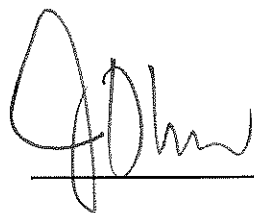
 2/28/2023

PLEASE RETURN COMPLETED FORM TO OKSANA KUZMUK

Check Approval Form

Date: March 29, 2023

District: Aberdeen CDD

Fund Code: 1

Beginning Check #: 50901

Ending Check #: 50904

Total Amount of Checks: \$ 738.80 New Balance
Balance in Account***: \$ 156,477.75 \$ 155,738.95

Recent Deposits: _____

Prepared by: Daniel Laughlin

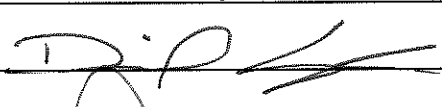
Signature:  _____

Approved by: Jim Oliver

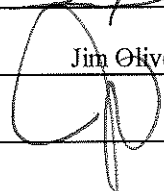
Signature:  _____

CHECK #	EMP #	EMPLOYEE NAME	CHECK AMOUNT	CHECK DATE
50901	12	ANGELA MARIE ANDREWS	184.70	3/29/2023
50902	17	HARRIET S CLARKE	184.70	3/29/2023
50903	15	LAUREN Q EGLESTON	184.70	3/29/2023
50904	16	THOMAS G MARMO	184.70	3/29/2023
TOTAL FOR REGISTER			738.80	

ABER ABERDEEN

DLAUGHLIN

ATTENDANCE SHEET

District: Aberdeen

Meeting Date: 03.28.23

	Supervisor	In Attendance	Fees
1.	Lauren Eggleston <i>Chairperson</i>	<input checked="" type="checkbox"/>	\$200
2.	Susie Clarke <i>Assistant Secretary</i>	<input checked="" type="checkbox"/>	\$200
3.	Thomas Marmo <i>Assistant Secretary</i>	<input checked="" type="checkbox"/>	\$200
4.	Paul Fogel <i>Vice Chairman</i>	<input type="checkbox"/>	\$200
5.	Angela Andrews <i>Assistant Secretary</i>	<input checked="" type="checkbox"/>	\$200

District Manager:

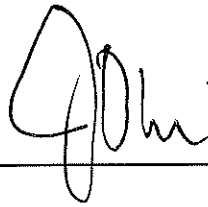

PLEASE RETURN COMPLETED FORM TO OKSANA KUZMUK

DATE CHECK	VEND#INVOICE.....	...EXPENSED TO...	VENDOR NAME	STATUS	AMOUNTCHECK.....CHECK.....
		DATE	INVOICE	YRMO DPT ACCT# SUB SUBCLASS			AMOUNT	#
3/09/23	00279	2/15/23	1523	202303 320-53800-45913	*	7,312.29		
				MAR LIFEGUARD SERVICES				
				ELITE AMENITIES NE FL, LLC			7,312.29	004586
3/09/23	00259	2/01/23	10867188	202302 320-53800-45918	*	698.00		
				FEB PROPERTY MANAGER				
		2/01/23	10867188	202302 320-53800-45915	*	698.00		
				FEB FRONT DESK				
		2/01/23	10867188	202302 320-53800-45917	*	698.00		
				FEB GROUNDS MAINTENANCE				
		2/01/23	10867188	202302 320-53800-45917	*	698.00		
				FEB MAINT SUPERVISOR				
		3/01/23	10870295	202303 320-53800-45921	*	1,075.00		
				MAR MANAGEMENT FEE				
		3/03/23	10871644	202302 320-53800-45918	*	3,096.10		
				FEB GENERAL MANAGER				
		3/03/23	10871644	202302 320-53800-45917	*	1,798.90		
				FEB STAFF BUILDING MAIN				
		3/03/23	10871644	202302 320-53800-45915	*	1,700.01		
				FEB STAFF FRONT DESK				
		3/03/23	10871644	202302 320-53800-45505	*	513.97		
				FEB STAFF GROUND MAINT				
		3/03/23	10871644	202302 320-53800-45506	*	988.23		
				FEB STAFF GROUND MAINT				
		3/03/23	10871644	202302 320-53800-46000	*	2,479.45		
				FEB SUPV BUILDING MAINT				
				FIRST SERVICE RESIDENTIAL			14,443.66	004587
3/09/23	00213	2/28/23	77226	202302 320-53800-46100	*	2,675.00		
				FEB LAKE MAINTENANCE				
				FUTURE HORIZONS, INC			2,675.00	004588
3/09/23	00017	3/01/23	2047	202303 310-51300-34000	*	4,399.67		
				MARCH MANANGEMENT FEES				
		3/01/23	2047	202303 310-51300-35100	*	150.00		
				MARCH INFO TECH				
		3/01/23	2047	202303 310-51300-31300	*	583.33		
				MARCH DISSEM AGENT SRVCS				
		3/01/23	2047	202303 310-51300-51000	*	.45		
				OFFICE SUPPLIES				
		3/01/23	2047	202303 310-51300-42000	*	9.00		
				POSTAGE				
		3/01/23	2047	202303 310-51300-42500	*	31.35		
				COPIES				
		3/01/23	2047	202303 310-51300-41000	*	34.28		
				TELEPHONE				
				GOVERNMENTAL MANAGEMENT SERVICES			5,208.08	004589

ABER ABERDEEN OKUZMUK

*** CHECK DATES 03/01/2023 - 03/31/2023 *** ABERDEEN - GENERAL FUND
BANK A ABERDEEN CDD

CHECK DATE	VEND#	INVOICE DATE	INVOICE	EXPENSED TO YRMO	DPT ACCT#	SUB SUBCLASS	VENDOR NAME	STATUS	AMOUNT	CHECK AMOUNT	CHECK #
3/09/23	00271	2/25/23	3183002	202301	310-51300-31500		JAN MONTHLY MEETING KUTAK ROCK LLP	*	1,716.35	1,716.35	004590
3/09/23	00079	3/01/23	13129561	202303	320-53800-45507		MARCH POOL CHEMICALS POOLSURE	*	2,717.01	2,717.01	004591
3/09/23	00192	2/22/23	81923	202303	320-57200-49400		DEPOSIT EVENT 3/14/23 PRINCE PELE'S POLYNESIAN REVUE	*	1,125.00	1,125.00	004592
3/09/23	00283	2/28/23	19789	202302	320-53800-46200		FEB LANDSCAPE MAINTENANCE TREE AMIGOS	*	21,547.38	21,547.38	004593
3/23/23	00286	2/01/23	5359894	202302	310-51300-48000		NOTICE OF MEETING 8392720 CA FLORIDA HOLDINGS,LLC	*	68.00	68.00	004594
3/23/23	00013	9/06/22	0204674	202210	310-51300-31100		PROFESS SRVC THRU 8/27/22	*	436.50		
		3/07/23	0207411	202302	310-51300-31100		PROFESS SRVC THRU 2/25/23 ENGLAND THIMS & MILLER, INC.	*	322.50	759.00	004595
3/23/23	00068	3/01/23	725666	202303	320-53800-45400		POOL MONITORING 4/01-6/30 HIDDEN EYES LLC DBA ENVERA SYSTEMS	*	2,772.00	2,772.00	004596
3/23/23	00299	3/15/23	1930	202303	320-53800-46300		CUT TALL DEAD PINE TREE	*	800.00		
		3/15/23	1931	202303	320-53800-46300		CUT 2 PINE TREES W/ VINES GENESIS TREE CARE LLC	*	700.00	1,500.00	004597
3/23/23	00295	3/20/23	196460	202303	320-57200-46000		RPR FENCE POSEY FAMILY OUTDOOR SERVICES	*	1,750.00	1,750.00	004598
3/23/23	00221	3/01/23	2902	202303	320-53800-45919		FEB MAINT AND NEWS LETTER ROBERTA G NAGLE DBA UNICORN	*	150.00	150.00	004599
3/23/23	00277	3/17/23	S86795	202303	320-57200-46000		RPR SYSTEM-NOT WORKING WEATHER ENGINEERS, INC.	*	288.20	288.20	004600

ABER ABERDEEN OKUZMUK

CHECK DATE	VEND#INVOICE..... DATE INVOICE	...EXPENSED TO... YRMO DPT ACCT# SUB SUBCLASS	VENDOR NAME	STATUS	AMOUNTCHECK..... AMOUNT #
3/31/23	00153	3/23/23	51509067 202303 320-57200-46000	FIRST AID/SAFETY	*	616.95	
				CINTAS FIRE 636525			616.95 004601
3/31/23	00259	3/17/23	10872835 202303 320-53800-45918	MAR GEN MNGR PROP OPER	*	3,096.10	
		3/17/23	10872835 202303 320-53800-45917	MAR STAFF FRONT DESK	*	1,812.83	
		3/17/23	10872835 202303 320-53800-45505	MAR STAFF GROUNDS MAINT	*	1,704.90	
		3/17/23	10872835 202303 320-53800-46000	MAR SUPVSR BUILD MAINT	*	2,609.56	
		3/17/23	10872835 202303 320-53800-46000	MAR STAFF BUILD MAINT	*	2,012.81	
		3/22/23	10873743 202303 320-53800-45918	PROPERTY MANAGER	*	698.00	
		3/22/23	10873743 202303 320-53800-45915	FRONT DESK	*	698.00	
		3/22/23	10873743 202303 320-53800-45917	GROUNDS MAINTENANCE	*	698.00	
		3/22/23	10873743 202303 320-53800-45917	MAINTENANCE SUPERVISOR	*	698.00	
				FIRST SERVICE RESIDENTIAL			14,028.20 004602
3/31/23	00283	1/30/23	19543 202301 320-53800-46200	JAN LANDSCAPE MAINTENANCE	*	21,547.38	
		3/28/23	20047 202303 320-53800-46200	MAR LANDSCAPE MAINT SRVC	*	21,547.38	
				TREE AMIGOS			43,094.76 004603
3/31/23	00303	2/07/23	1043 202303 320-57200-49400	4/8 EVT FACE PAINTING	*	256.00	
				GINA PEAVEY DBA WACKY AND WHIMSICAL			256.00 004604
				TOTAL FOR BANK A		122,027.88	
				TOTAL FOR REGISTER		122,027.88	

Check Approval Form

General Fund

Date: March 9, 2023

District: Aberdeen CDD GF

Fund Code: 1

Beginning Check #: 4586

Ending Check #: 4593

Total Amount of Checks:	\$ 56,744.77	New Balance
Balance in Account***:	\$ 239,020.63	\$ 182,275.86

Recent Deposits: _____

Prepared by: Todd R. Polvere

Signature: 

Approved by: Jim Oliver

Signature: _____

BANK A: ABERDEEN CDD

VEND NO.	Invoice Date	Vendor Inv. No.	---General Ledger#-----	St Cr	DUE DATE	GROSS AMOUNT	DISC AMOUNT	NET AMOUNT	CHECK PO#	CHECK NO.
00279	21523	1523	001-320-53800-45913		21523	7,312.29	.00	7,312.29		
			MAR LIFEGUARD SERVICES							
			ELITE AMENITIES NE FL, LLC			7,312.29	.00	7,312.29	004586	
00259	20123	10867188	001-320-53800-45918		20123	698.00	.00	698.00		
			FEB PROPERTY MANAGER							
00259	20123	10867188	001-320-53800-45915		20123	698.00	.00	698.00		
			FEB FRONT DESK							
00259	20123	10867188	001-320-53800-45917		20123	698.00	.00	698.00		
			FEB GROUNDS MAINTENANCE							
00259	20123	10867188	001-320-53800-45917		20123	698.00	.00	698.00		
			FEB MAINT SUPERVISOR							
00259	30123	10870295	001-320-53800-45921		30123	1,075.00	.00	1,075.00		
			MAR MANAGEMENT FEE							
00259	30323	10871644	001-320-53800-45918		30323	3,096.10	.00	3,096.10		
			FEB GENERAL MANAGER							
00259	30323	10871644	001-320-53800-45917		30323	1,798.90	.00	1,798.90		
			FEB STAFF BUILDING MAIN							
00259	30323	10871644	001-320-53800-45915		30323	1,700.01	.00	1,700.01		
			FEB STAFF FRONT DESK							
00259	30323	10871644	001-320-53800-45505		30323	513.97	.00	513.97		
			FEB STAFF GROUND MAINT							
00259	30323	10871644	001-320-53800-45506		30323	988.23	.00	988.23		
			FEB STAFF GROUND MAINT							
00259	30323	10871644	001-320-53800-46000		30323	2,479.45	.00	2,479.45		
			FEB SUPV BUILDING MAINT							
			FIRST SERVICE RESIDENTIAL			14,443.66	.00	14,443.66	004587	
00213	22823	77226	001-320-53800-46100		22823	2,675.00	.00	2,675.00		
			FEB LAKE MAINTENANCE							
			FUTURE HORIZONS, INC			2,675.00	.00	2,675.00	004588	
00017	30123	2047	001-310-51300-34000		30123	4,399.67	.00	4,399.67		
			MARCH MANANGEMENT FEES							
00017	30123	2047	001-310-51300-35100		30123	150.00	.00	150.00		
			MARCH INFO TECH							
00017	30123	2047	001-310-51300-31300		30123	583.33	.00	583.33		
			MARCH DISSEM AGENT SRVCS							
00017	30123	2047	001-310-51300-51000		30123	.45	.00	.45		
			OFFICE SUPPLIES							
00017	30123	2047	001-310-51300-42000		30123	9.00	.00	9.00		
			POSTAGE							
00017	30123	2047	001-310-51300-42500		30123	31.35	.00	31.35		
			COPIES							
00017	30123	2047	001-310-51300-41000		30123	34.28	.00	34.28		
			TELEPHONE							
			GOVERNMENTAL MANAGEMENT SERVICES			5,208.08	.00	5,208.08	004589	
00271	22523	3183002	001-310-51300-31500		22523	1,716.35	.00	1,716.35		

ABER ABERDEEN TPOLVERE

BANK A: ABERDEEN CDD

VEND NO.	Invoice Date	Vendor Inv. No.	---General Ledger#-----	St	Cr	DUE DATE	GROSS AMOUNT	DISC AMOUNT	NET AMOUNT	CHECK PO#	CHECK NO.
JAN MONTHLY MEETING											
		KUTAK ROCK LLP					1,716.35	.00	1,716.35	004590	
			ATTORNEY FEES								
00079	30123	13129561	001-320-53800-45507			30123	2,717.01	.00	2,717.01		
MARCH POOL CHEMICALS			AMENITY - POOL CHEMICALS				2,717.01	.00	2,717.01	004591	
		POOLSURE									
00192	22223	81923	001-320-57200-49400			22223	1,125.00	.00	1,125.00		
DEPOSIT EVENT	3/14/23		SPECIAL EVENTS				1,125.00	.00	1,125.00	004592	
		PRINCE PELE'S POLYNESIAN REVUE									
00283	22823	19789	001-320-53800-46200			22823	21,547.38	.00	21,547.38		
FEB LANDSCAPE MAINTENANCE			LANDSCAPE MAINTENANCE				21,547.38	.00	21,547.38	004593	
		TREE AMIGOS									
ABERDEEN CDD							56,744.77	.00	56,744.77		
ABERDEEN - GENERAL FUND							56,744.77	.00	56,744.77		

Elite Amenities NE FL, LLC

4116 Running Bear Lane
Saint Johns, FL 32259 US
904-710-0172
eric@eliteamenities.com

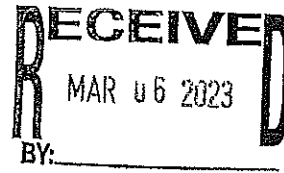

INVOICE

BILL TO
Belynda Tharpe
Aberdeen Amenity Center
110 Flower of Scotland Ave.
St. Johns, FL 32259

INVOICE 1523
DATE 02/15/2023
TERMS Net 15
DUE DATE 03/01/2023

DATE	DESCRIPTION	QTY	RATE	AMOUNT
	Lifeguards - March	1	7,312.29	7,312.29

BALANCE DUE **\$7,312.29**

320.538.45913
Lifeguard
Contract
CS

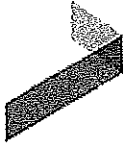

FirstService
RESIDENTIAL

Aberdeen Community Development District
110 Flower of Scotland Avenue
Saint Johns, FL 32259
Anh.Nguyen@fsresidential.com

INVOICE

Invoice Number 10867188
 Invoice Date 2/23/2023
 Terms 15 ePay ACH BP
 Period Begin 2/1/2023
 Customer 100-0SNC
 Account # MED-0SNC
Total Amount Due: \$2,792.00

Medical Insurance

Date	Position	Employee	Amount
2/1/2023	Property Manager	Trivelpiece, Katherine	\$698.00
			Subtotal \$698.00
2/1/2023	Front Desk	Arnold, Demetric E	\$698.00
			Subtotal \$698.00
2/1/2023	Grounds Maintenance	Abshire, Caleb L	\$698.00
			Subtotal \$698.00
2/1/2023	Maintenance Supervisor	Parker, Jay	\$698.00
			Subtotal \$698.00
			Subtotal \$2,792.00
			Tax \$0.00
			Total \$2,792.00

RECEIVED
 FEB 28 2023
 BY: _____

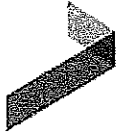

FirstService
RESIDENTIAL

Aberdeen Community Development District
110 Flower of Scotland Avenue
Saint Johns, FL 32259
Anh.Nguyen@fsresidential.com

INVOICE

Invoice Number 10870295
Invoice Date 3/1/2023
Terms 15 ePay ACH BP
Service Period 3/1/2023
Customer 100-0SNC

Invoice Type MGFEE
Account # MGF-0SNC
Total Amount Due: \$1,075.00

1,320,538.45921

Description	Total
Management Fee	\$1,075.00
<hr/>	
Subtotal	\$1,075.00
Tax	\$0.00
Total	\$1,075.00

RECEIVED
MAR 03 2023
BY: _____

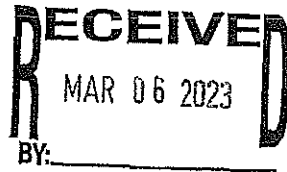
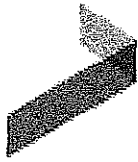

INVOICE

FirstService RESIDENTIAL

Aberdeen Community Development District
110 Flower of Scotland Avenue
Saint Johns, FL 32259
Anh.Nguyen@fsresidential.com

Invoice Number 10871644
Invoice Date 3/3/2023
Terms 15 ePay ACH BP
Period Start 2/11/2023
Period End 2/24/2023

Customer 100-0SNC
Account # PAY-0SNC
Total Amount Due: \$10,576.66

Position	Labor Rate	Employee	Hours	Pay Rate	Amount
General Manager, Property Oper	15.00%	Trivelpiece, Katherine	8.00 HOLIDAY	\$33.65	\$309.61
General Manager, Property Oper	15.00%	Trivelpiece, Katherine	72.00 REGULAR	\$33.65	\$2,786.49
Subtotal					\$3,096.10
Staff, Front Desk	25.00%	Arnold, Demetric E	8.00 HOLIDAY	\$17.00	\$170.00
Staff, Front Desk	25.00%	Arnold, Demetric E	5.33 PTO	\$17.00	\$113.26
Staff, Front Desk	25.00%	Arnold, Demetric E	66.67 REGULAR	\$17.00	\$1,416.75
Subtotal					\$1,700.01
Staff, Grounds Maint	25.00%	Abshire, Caleb L	8.00 HOLIDAY	\$16.00	\$160.00
Staff, Grounds Maint	25.00%	Abshire, Caleb L	4.35 HOLIDAY ST	\$16.00	\$87.00
Staff, Grounds Maint	25.00%	Abshire, Caleb L	62.76 REGULAR	\$16.00	\$1,255.20
Subtotal					\$1,502.20
Supervisor, Building Maint	25.00%	Parker, Jay	8.00 HOLIDAY	\$26.00	\$260.00
Supervisor, Building Maint	25.00%	Parker, Jay	68.29 REGULAR	\$26.00	\$2,219.45
Subtotal					\$2,479.45
Staff, Building Maint	25.00%	Henry, Brandon E	8.00 HOLIDAY	\$18.50	\$185.00
Staff, Building Maint	25.00%	Henry, Brandon E	69.79 REGULAR	\$18.50	\$1,613.90

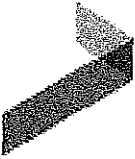

FirstService

RESIDENTIAL

Aberdeen Community Development District
110 Flower of Scotland Avenue
Saint Johns, FL 32259
Anh.Nguyen@fsresidential.com

INVOICE

Invoice Number 10871644
 Invoice Date 3/3/2023
 Terms 15 ePay ACH BP
 Period Start 2/11/2023
 Period End 2/24/2023
 Customer 100-OSNC
 Account # PAY-OSNC
Total Amount Due: \$10,576.66

Position	Labor Rate	Employee	Hours	Pay Rate	Amount
Subtotal					\$1,798.90

Subtotal					\$10,576.66
Tax					\$0.00
Total					\$10,576.66

General Manager, Property Oper	\$3,096.10		1.320.538.45918		
Staff, Building Maint	\$1,798.90		1.320.538.45917		
Staff, Front Desk	\$1,700.01		1.320.538.45915		
Staff, Grounds Maint	\$1,502.20				
Supervisor, Building Maint	\$2,479.45		1.320.538.460		

\$513.97 1.320.538.45505
 \$988.23 1.320.538.45506

Future Horizons, Inc

403 N First Street
 PO Box 1115
 Hastings, FL 32145
 USA

Voice: 904-692-1187
 Fax: 904-692-1193

INVOICE

Invoice Number: 77226
 Invoice Date: Feb 28, 2023
 Page: 1

Bill To:
Aberdeen CDD 475 West Town Place Suite 114 St. Augustine, FL 32092

Ship to:
Aberdeen CDD 475 West Town Place Suite 114 St. Augustine, FL 32092

Customer ID	Customer PO	Payment Terms	
Aberdeen01	Per Contract	Net 30 Days	
Sales Rep ID	Shipping Method	Ship Date	Due Date
	Hand Deliver		3/30/23

Quantity	Item	Description	Unit Price	Amount
1.00	Aquatic Weed Control	Aquatic Weed Control services performed in February 2023 1,320,538.461 RECEIVED FEB 28 2023 BY: _____	2,675.00	2,675.00
Subtotal				2,675.00
Sales Tax				
Freight				
Total Invoice Amount				2,675.00
Payment/Credit Applied				
TOTAL				2,675.00

Check/Credit Memo No:

Overdue invoices are subject to finance charges.

Governmental Management Services, LLC
 1001 Bradford Way
 Kingston, TN 37763

Invoice

Invoice #: 2047
 Invoice Date: 3/1/23
 Due Date: 3/1/23
 Case:
 P.O. Number:

RECEIVED
 MAR 03 2023
 BY: _____

Bill To:
 Aberdeen CDD
 475 West Town Place
 Suite 114
 St. Augustine, FL 32092

Description	Hours/Qty	Rate	Amount
Management Fees - March 2023	1,310.513	3.40	4,399.67
Information Technology - March 2023	351	150.00	150.00
Dissemination Agent Services - March 2023	313	583.33	583.33
Office Supplies	510	0.45	0.45
Postage	420	9.00	9.00
Copies	425	31.35	31.35
Telephone	410	34.28	34.28

Total \$5,208.08

Payments/Credits \$0.00

Balance Due \$5,208.08

KUTAK ROCK LLP

TALLAHASSEE, FLORIDA

Telephone 404-222-4600

Facsimile 404-222-4654

Federal ID 47-0597598

February 25, 2023

Check Remit To:

Kutak Rock LLP

PO Box 30057

Omaha, NE 68103-1157

Wire Transfer Remit To:

ABA #104000016

First National Bank of Omaha

Kutak Rock LLP

A/C # 24690470

Reference: Invoice No. 3183002

Client Matter No. 223-2

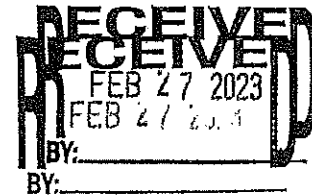

Mr. Jim Oliver
Aberdeen CDD
Governmental Management Services - North Florida
Suite 114
475 West Town Place
St. Augustine, FL 32092

Invoice No. 3183002

223-2

1,310,513.315

Re: Aberdeen CDD - Monthly Meeting

For Professional Legal Services Rendered

01/20/23	W. Haber	Prepare for and participate in conference call regarding January meeting
01/24/23	W. Haber	Prepare for and participate in Board meeting

TOTAL FOR SERVICES RENDERED \$1,500.00

DISBURSEMENTS

Meals	17.18
Travel Expenses	199.17

TOTAL DISBURSEMENTS 216.35

TOTAL CURRENT AMOUNT DUE \$1,716.35



1707 Townhurst Dr.
Houston TX 77043
(800) 858-POOL (7665)
www.poolsure.com

Invoice

Date 3/1/2023

Invoice # 131295612969

Terms	Net 20
Due Date	3/21/2023
PO #	

Bill To GMS LLC Aberdeen CDD 475 West Town Place Suite 114 St. Augustine FL 32092	Ship To Aberdeen CDD 110 Flowers of Scotland Jacksonville FL 32259
---	--

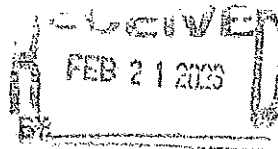
Item ID	Description	Qty	Units	Amount
WM-CHEM-FLAT	Water Management Flat Billing Rate	1	ea	2,646.54
WM-SHED RENTAL	Monthly rental fee for storage shed	1	ea	10.00
Fuel Surcharge	Fuel/Environmental Transit Fee	1	ea	60.47
<p>1,320.538.45507</p> 				

Subtotal 2,717.01
 Shipping Cost (FEDEX GROUND) 0.00
 Total 2,717.01
 Amount Due \$2,717.01

Remittance Slip

Customer
13ABE100
Invoice #
131295612969

Amount Due \$2,717.01

Amount Paid _____

Make Checks Payable To
Poolsure
PO Box 55372
Houston, TX 77255-5372



131295612969



Prince Pele's Polynesian Revue
Hula-Show.com

(904) 699-3472 cell

\$ INVOICE \$

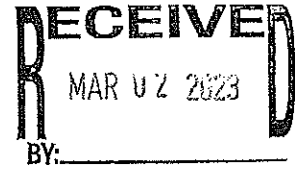

February 22, 2023

INVOICE NO: 81923

PAYEE:

PRINCE PELE'S POLYNESIAN REVUE
Blesila Fuata
1132 Hyacinth St.
St. Augustine, FL 32092

FEDERAL EMPLOYER ID NUMBER: 59-6587125

TYPE OF SERVICE: Entertainment for ABERDEEN Residence

FEE FOR SERVICES RENDERED: \$2,250.00

~~DEPOSIT~~ \$ 1,125.00 (Due by 3/14/23)

BALANCE : \$ 1,125.00 DUE ON DATE OF EVENT

DATE OF SERVICE (to be) PERFORM (ed): August 19, 2023

*Special Events
320.572.49400
lcs*



Tree Amigos

Outdoor Services

Invoice

Invoice#: 19789

Date: 02/28/2023

Billed To: Aberdeen CDD
475 W Town Place
#114
St. Augustine FL 32092

Project: Aberdeen CDD
571 Market St
St. Augustine FL 32095

Description	Quantity	Price	Ext Price
February Monthly Landscape Maintenance	1.00	21,547.38	21,547.38

Notes:

Invoice Total: \$21,547.38

*Landscape Cont.
320.53800. 46200
KD*

RECEIVED
MAR 6 2 2023
BY: _____

Check Approval Form

General Fund

Date: March 23, 2023

District: Aberdeen CDD

Fund Code: 1

Beginning Check #: 4594

Ending Check #: 4600

Total Amount of Checks: \$ 7,287.20

New Balance
\$ 156,477.75

Balance in Account***: \$ 163,764.95

Recent Deposits: _____

Prepared by: Todd R. Polvere

Signature: 

Approved by: Jim Oliver

Signature: _____

BANK A: ABERDEEN CDD

VEND NO.	Invoice Date	Vendor Inv. No.	---General Ledger#-----	St Cr	DUE DATE	GROSS AMOUNT	DISC AMOUNT	NET AMOUNT	CHECK PO#	CHECK NO.
00286	20123	5359894	001-310-51300-48000		20123	68.00	.00	68.00		
NOTICE OF MEETING 8392720 LEGAL ADVERTISING CA FLORIDA HOLDINGS,LLC						68.00	.00	68.00	004594	
00013	90622	0204674	001-310-51300-31100		90622	436.50	.00	436.50		
PROFESS SRVC THRU 8/27/22 ENGINEERING FEES										
00013	30723	0207411	001-310-51300-31100		30723	322.50	.00	322.50		
PROFESS SRVC THRU 2/25/23 ENGINEERING FEES ENGLAND THIMS & MILLER, INC.						759.00	.00	759.00	004595	
00068	30123	725666	001-320-53800-45400		30123	2,772.00	.00	2,772.00		
POOL MONITORING 4/01-6/30 SECURITY HIDDEN EYES LLC DBA ENVERA SYSTEMS						2,772.00	.00	2,772.00	004596	
00299	31523	1930	001-320-53800-46300		31523	800.00	.00	800.00		
CUT TALL DEAD PINE TREE LANDSCAPE CONTINGENCY										
00299	31523	1931	001-320-53800-46300		31523	700.00	.00	700.00		
CUT 2 PINE TREES W/ VINES LANDSCAPE CONTINGENCY GENESIS TREE CARE LLC						1,500.00	.00	1,500.00	004597	
00295	32023	196460	001-320-57200-46000		32023	1,750.00	.00	1,750.00		
RPR FENCE REPAIRS AND REPLACEMENTS POSEY FAMILY OUTDOOR SERVICES						1,750.00	.00	1,750.00	004598	
00221	30123	2902	001-320-53800-45919		30123	150.00	.00	150.00		
FEB MAINT AND NEWS LETTER AMENITY - WEBSITE ROBERTA G NAGLE DBA UNICORN						150.00	.00	150.00	004599	
00277	31723	S86795	001-320-57200-46000		31723	288.20	.00	288.20		
RPR SYSTEM-NOT WORKING REPAIRS AND REPLACEMENTS WEATHER ENGINEERS, INC.						288.20	.00	288.20	004600	
ABERDEEN CDD						7,287.20	.00	7,287.20		
ABERDEEN - GENERAL FUND						7,287.20	.00	7,287.20		

ABER ABERDEEN

TPOLVERE

LOCALiQ

FLORIDA

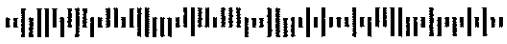
ACCOUNT NAME Aberdeen Cdd/Gms		ACCOUNT # 764138	PAGE # 1 of 1
INVOICE # 0005359894	BILLING PERIOD Feb 1- Feb 28, 2023	PAYMENT DUE DATE March 20, 2023	
PREPAY (Memo Info) \$0.00	UNAPPLIED (Included in amt due) \$0.00	TOTAL AMOUNT DUE \$136.00	
BILLING ACCOUNT NAME AND ADDRESS Aberdeen Cdd/Gms 393 Palm Coast Pkwy. S.W. Unit 4 Palm Coast, FL 32137-4774 		BILLING INQUIRIES/ADDRESS CHANGES 1-877-736-7612 or smb@ccc.gannett.com	FEDERAL ID 47-2390983
<p>Legal Entity: Gannett Media Corp. Terms and Conditions: Past due accounts are subject to interest at the rate of 18% per annum or the maximum legal rate (whichever is less). Advertiser claims for a credit related to rates incorrectly invoiced or paid must be submitted in writing to Publisher within 30 days of the invoice date or the claim will be waived. Any credit towards future advertising must be used within 30 days of issuance or the credit will be forfeited. All funds payable in US dollars.</p>			

00007641380000000000000053598940001360067178

To sign-up for E-mailed invoices and online payments please contact abgspecial@gannett.com. Previous account number: MOR 1565

Date	Description	Amount
2/1/23	Balance Forward	\$68.00

Start-End Date	Order Number	Description	PO Number	Package Cost
2/20/23	8392720	Aberdeen CDD - February Meeting		\$68.00

1,310,513,480

RECEIVED
MAR 15 2023
By _____

~~**PAID**~~
MAR 26 2023

PLEASE DETACH AND RETURN THIS PORTION WITH YOUR PAYMENT

LOCALiQ

FLORIDA

ACCOUNT NAME Aberdeen Cdd/Gms	PAYMENT DUE DATE March 20, 2023	AMOUNT PAID
ACCOUNT NUMBER 764138	INVOICE NUMBER 0005359894	

CURRENT DUE	30 DAYS PAST DUE	60 DAYS PAST DUE	90 DAYS PAST DUE	120+ DAYS PAST DUE	UNAPPLIED PAYMENTS	TOTAL AMOUNT DUE
\$68.00	\$68.00	\$0.00	\$0.00	\$0.00	\$0.00	\$136.00

REMITTANCE ADDRESS (Include Account# & Invoice# on check)

CA Florida Holdings, LLC
PO Box 631244
Cincinnati, OH 45263-1244

TO PAY WITH CREDIT CARD PLEASE FILL OUT BELOW:

VISA MASTERCARD DISCOVER AMEX

Card Number _____
Exp Date ____ / ____ / ____ CVV Code _____
Signature _____ Date _____

00007641380000000000000053598940001360067178

LOCALIQ

FLORIDA

PO Box 631244 Cincinnati, OH 45263-1244

PROOF OF PUBLICATION

Aberdeen Cdd/Gms
Aberdeen Cdd/Gms
393 Palm Coast Pkwy Sw
SUITE 4

Palm Coast FL 32137

STATE OF FLORIDA, COUNTY OF ST JOHNS

The St Augustine Record, a daily newspaper published in St Johns County, Florida; and of general circulation in St Johns County; and personal knowledge of the facts herein state and that the notice hereto annexed was Published in said newspapers in the issues dated or by publication on the newspaper's website, if authorized, on:

02/20/2023

and that the fees charged are legal.
Sworn to and subscribed before on 02/20/2023

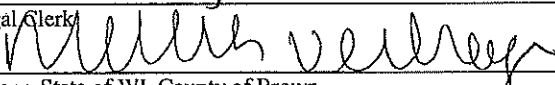

Legal Clerk

Notary, State of WI, County of Brown
8.25.26

My commission expires

Publication Cost: \$68.00

Order No: 8392720

of Copies:

Customer No: 764138

1

PO #:

THIS IS NOT AN INVOICE!

Please do not use this form for payment remittance.

MARIAH VERHAGEN
Notary Public
State of Wisconsin

NOTICE OF MEETING ABERDEEN COMMUNITY DEVELOPMENT DISTRICT

The meeting of the Board of Supervisors (the "Board") of the Aberdeen Community Development District is scheduled to be held on Tuesday, February 28, 2023 at 6:00 p.m. located at the Aberdeen Amenity Center, 110 Flower of Scotland Avenue, Saint Johns, Florida 32259. The meeting is open to the public and will be conducted in accordance with the provisions of Florida Law for Community Development Districts. A copy of the agenda for this meeting may be obtained from the District Manager, 475 West Town Place, Suite 114, World Golf Village, St. Augustine, Florida 32092 (and phone (904) 940-5850). This meeting may be continued to a date, place and time certain, to be announced at the meeting. There may be occasions when one or more Supervisors will participate by telephone.

Any person requiring special accommodations at this meeting because of a disability or physical impairment should contact the District Manager at (904) 940-5850 at least two calendar days prior to the meeting. If you are hearing or speech impaired, please contact the Florida Relay Service at 1-800-955-8770, for aid in contacting the District Office. Each person who decides to appeal any action taken at this meeting is advised that person will need a record of proceedings and that accordingly, the person may need to ensure that a verbatim record of the proceedings is made, including the testimony and evidence upon which such appeal is to be based.

James Oliver
District Manager
St. Augustine 11 02/20/2023

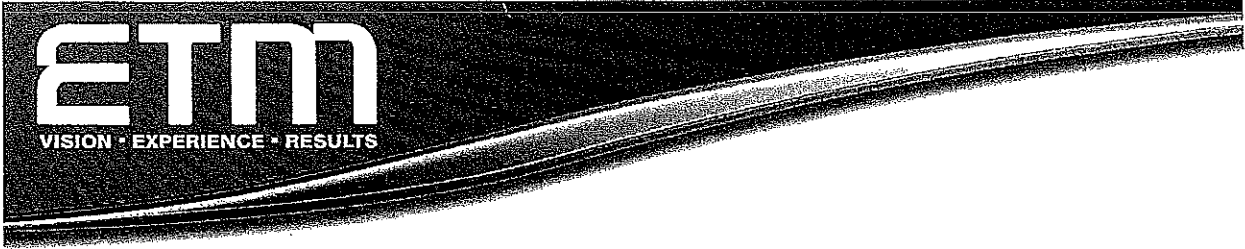

Aberdeen Community Development District (CDD)
 c/o GMS, LLC
 475 West Town Place
 Suite 114
 St. Augustine, FL 32092

September 06, 2022
 Project No: 02105.27000
 Invoice No: 0204674

Project 02105.27000 Aberdeen Community Development District-2018/2019 General
 Consulting Engineering Services (WA#27)

Professional Services rendered through August 27, 2022

Task	01	Professional Services	Hours	Rate	Amount
Professional Personnel					
Senior Engineer					
Katsaras, George	8/27/2022		2.25	194.00	436.50
Totals			2.25		436.50
Total Labor					436.50
Total this Task					\$436.50

Task	XP	Expenses	Total this Task
			0.00

Invoice Total this Period \$436.50

1,310,513.311

RECEIVED
 MAR 09 2023
 BY: _____

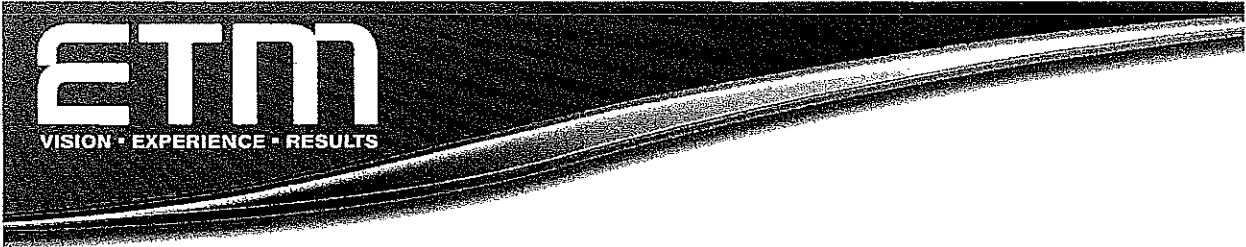

Aberdeen Community Development District (CDD)
 c/o GMS, LLC
 475 West Town Place
 Suite 114
 St. Augustine, FL 32092

March 07, 2023
 Project No: 02105.27000
 Invoice No: 0207411

Project 02105.27000 Aberdeen Community Development District-2018/2019 General
 Consulting Engineering Services (WA#27)

Professional Services rendered through February 25, 2023

Task 01 Professional Services

Professional Personnel

			Hours	Rate	Amount	
Senior Engineer						
Katsaras, George	2/25/2023		1.50	215.00	322.50	
Totals			1.50		322.50	
Total Labor						322.50
				Total this Task		\$322.50

Task XP Expenses **Total this Task 0.00**

1,310.513.311

Invoice Total this Period \$322.50

Outstanding Invoices

Number	Date	Balance
0204674	9/6/2022	436.50
Total		436.50

RECEIVED
 MAR 09 2023
 BY: _____

Envera
 8281 Blaikie Court
 Sarasota, FL 34240
 (941) 556-0731

Invoice	
Invoice Number 725666	Date 03/01/2023
Customer Number 400171	Due Date 04/01/2023

Page 1

Customer Name	Customer Number	P.O. Number	Invoice Number	Due Date
Aberdeen CDD	400171		725666	04/01/2023
Quantity	Description		Rate	Amount
3.00	Aberdeen CDD, 110 Flower of Scotland Ave, Jacksonville, FL Pool Monitoring 04/01/2023 - 06/30/2023		924.00	2,772.00
	Sales Tax			0.00
	Payments/Credits Applied			0.00
Invoice Balance Due:				\$2,772.00

IMPORTANT MESSAGES

Important Numbers to Know:

Billing Questions: (941) 556-0743
 Email: ar@enverasystems.com
 Service: (941) 556-0734

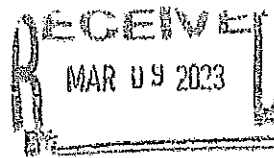

Date	Invoice #	Description	Amount	Balance Due
03/01/2023	725666	Alarm Monitoring Services	\$2,772.00	\$2,772.00

Envera
 8281 Blaikie Court
 Sarasota, FL 34240
 (941) 556-0731

Return Service Requested

Invoice	
Invoice Number 725666	Date 03/01/2023
Customer Number 400171	Due Date 04/01/2023

Net Due: \$2,772.00

Amount Enclosed: _____

 ABERDEEN CDD
 C/O GMS, LLC
 475 W TOWN PL STE 114
 SAINT AUGUSTINE, FL 32092-3849

2284

REMIT TO:

Envera
 PO Box 2086
 Hicksville, NY 11802



Genesis Tree Care
6326 Victoria Park Court
Jacksonville, FL 32216
contactus@genestreecare.com
http://www.genestreecare.com/

RECEIVED
MAR 15 2023
BY: _____

BILL TO
Jay Parker
FSResidential
544 Gramplan Highlands Drive
St. Johns, FL 32259 USA

INVOICE 1930

DATE 03/15/2023 **TERMS** Due upon
Completion

DUE DATE 03/16/2023

1,320.538,463

DATE	ACTIVITY	DESCRIPTION	QTY	RATE	AMOUNT
	Tree Removal	Cut and leave tall dead pine in backyard and leave in preserve area.	1	800.00	800.00

Payment is required upon completion of work. Late fees will be accessed at the rate of 1.5% per month starting 30 days after delivery of the invoice.

Returned Check Policy: \$35 returned check fee will apply.

Cancellation Policy: Genesis must be given a 24 hour notice of cancellation or a \$500 fee will apply.

TOTAL DUE

\$800.00



Genesis Tree Care
6326 Victoria Park Court
Jacksonville, FL 32216
contactus@genestreecare.com
http://www.genestreecare.com/

RECEIVED
MAR 15 2023
BY: _____

BILL TO
494 S Aberdeenshire Drive
St. Johns, FL 32259 USA

INVOICE 1931

DATE 03/15/2023 **TERMS** Due upon
Completion

DUE DATE 03/16/2023

1,320.538.463

DATE	ACTIVITY	DESCRIPTION	QTY	RATE	AMOUNT
	Tree Removal	Cut down and leave in preserve area 2 pine trees covered in vines.	1	700.00	700.00

Payment is required upon completion of work. Late fees will be accessed at the rate of 1.5% per month starting 30 days after delivery of the invoice.

Returned Check Policy: \$35 returned check fee will apply.

Cancellation Policy: Genesis must be given a 24 hour notice of cancellation or a \$500 fee will apply.

TOTAL DUE

\$700.00

Posey Family Outdoor Services

228 Little Owl Lane
 Saint Augustine, FL 32086 US
 804-347-8915
 poseyfamily1925@gmail.com
 https://poseyfos.com



INVOICE

BILL TO
 Aberdeen CDD
 Jay Parker
 110 Flower Of Scotland
 Fruit Cove, FL 32259

SHIP TO
 Aberdeen CDD
 Jay Parker
 110 Flower Of Scotland
 Fruit Cove, FL 32259

INVOICE 198460
DATE 03/20/2023
TERMS Due on receipt
DUE DATE 03/20/2023

DATE	ACTIVITY	DESCRIPTION	AMOUNT
	Fence Repair	Found entire fence extremely loose, as well as gaps at the bottom of the fence around the entire perimeter of fence. Found tension wire missing at the bottom of the fence causing the bottom of the fence to lift up. Remove 356 feet of black vinyl fencing to restore entire fence. Stretch back to create a solid dog fenced in area. Install tension wire around entire fence. Lower fence where needed to close off gap and make dog park secure.	1,750.00

RECEIVED
 MAR 21 2023
 BY: _____

320.572.46000
~~*300.538.46000*~~ *US*
US
 Repair's
 Replacement

SUBTOTAL	1,750.00
TAX	0.00
TOTAL	1,750.00
BALANCE DUE	\$1,750.00

Invoice



P.O. Box 762,
Middleburg, FL 32050

Date	Invoice #
3/1/2023	2902

Bill To
GOVERNMENTAL MANAGEMENT SERVICES, LLC ABERDEEN CDD 475 WEST TOWN PLACE, SUITE 114 WORLD GOLF VILLAGE ST. AUGUSTINE, FL 32092

P.O. No.	Terms	Project

Quantity	Description	Rate	Amount
1	MONTHLY MAINTENANCE AND NEWSLETTER - ABERDEEN CDD FOR FEBRUARY 2023 1,320.538.45919 RECEIVED MAR 09 2023 BY: _____	150.00	150.00
		Total	\$150.00



Weather Engineers, Inc.
 PO Box 37068
 Jacksonville, FL 32236
 Phone: (904) 356-3963
 Fax: (904) 356-4969
 www.weatherengineers.com
 CAC041190

Invoice

Number	Date
S86795	03/17/23

BILL TO: #105221

ABERDEEN CDD
 475 W. TOWN PALCE STE 114
 ST. AUGUSTINE FL 32092

SERVICE PERFORMED AT:

ABERDEEN FITNESS CENTER
 110 FLOWER OF SCOTLAND AVE
 ST. JOHNS FL 32259

1.320.572.460

Site #: 105221-001

Return this portion with payment

Amount Paid: _____

Work Order Date	Call Slip Number	P.O. Number	Salesman	Terms	Contract #	Batch #
03/15/23	180086			30		
DESCRIPTION						
Reported by: Jay Parker 904 303-7366 Trouble Code: MIS - MISC REPAIR billable/unit is on heat has burning smell & setting off alarm then unit shuts off/avail all day till 6/loc Amenity Center BRAND [MODEL # / SERIAL #] SERVING AREA AAON H3-CRB-8-0-162C / 202010-CJEC06 FITNESS CENTER FITNESS CENTER Diagnostic: (1) Upon arrival smoke detector audio/strobe in ceiling was detached from ceiling and red low voltage to audio/strobe unit disconnected. (2) In AAON FAN COIL control panel a jumper wire installed by another A/C company over the weekend between GND red wire and one black wire, and one white wire twisted together. Action: I removed jumper wire connected in AAON control panel, reset and tested smoke detector in attic at fan coil mount audio/strobe smoke detector unit in ceiling, connect red wire, reset unit then check A/C operations, everything checked out ok.						
TECH	DATE	RECEIVED	ARRIVED	DEPARTED		
104	03/15/23	13:45:00	14:58:00	16:35:00		
03/15/23	1 MECH	R/T	1.62 HRS @	110.00	178.20	
03/15/23	1 MECH	T/T	1.00 HRS @	110.00	110.00	
Continued on page 2						

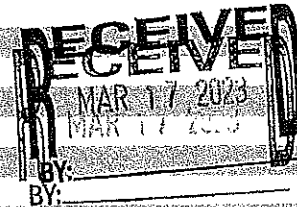

Thank you for your business!!

Please make all checks payable to Weather Engineers, Inc.
 Remit to: PO Box 37068 Jacksonville, FL 32236
 Phone (904) 356-3963 • Fax (904) 356-4969

We are an equal opportunity employer and do not discriminate against applicants due to race, gender, veterans status, or on the basis of disability or any other federal, state or local protected class. THIS CONTRACTOR AND SUBCONTRACTOR SHALL ABIDE BY THE REQUIREMENTS OF 41 CFR 90-300.5 (A). THIS REGULATION PROHIBITS DISCRIMINATION AGAINST QUALIFIED PROTECTED VETERANS, AND REQUIRES AFFIRMATIVE ACTION BY COVERED PRIME CONTRACTORS AND SUBCONTRACTORS TO EMPLOY AND ADVANCE IN EMPLOYMENT QUALIFIED PROTECTED VETERANS.



Weather Engineers, Inc.
 PO Box 37068
 Jacksonville, FL 32236
 Phone: (904) 356-3963
 Fax: (904) 356-4969
 www.weatherengineers.com
 CAC041190

Invoice

Number	Date
S86795	03/17/23

BILL TO: #105221

ABERDEEN CDD
 475 W. TOWN PALCE STE 114
 ST. AUGUSTINE FL 32092

SERVICE PERFORMED AT:

ABERDEEN FITNESS CENTER
 110 FLOWER OF SCOTLAND AVE
 ST. JOHNS FL 32259

Site #: 105221-001

Return this portion with payment **Amount Paid:** _____

Work Order Date	Call Slip Number	P.O. Number	Salesman	Terms	Contract #	Batch #
03/15/23	180086			30		
DESCRIPTION						
Continued from page 1						
03/15/23	1 MECH	N/C	.22 HRS @	110.00		.00
LABOR						288.20
TOTAL \$						288.20

Thank you for your business!!
 Please make all checks payable to Weather Engineers, Inc.
 Remit To: PO Box 37068 Jacksonville, FL 32236
 Phone (904) 356-3963* Fax (904) 356-4969

We are an equal opportunity employer and do not discriminate against applicants due to race, gender, veterans status, or on the basis of disability or any other federal, state or local protected class. THIS CONTRACTOR AND SUBCONTRACTOR SHALL ABIDE BY THE REQUIREMENTS OF 41 CFR 60-300.5 (A). THIS REGULATION PROHIBITS DISCRIMINATION AGAINST QUALIFIED PROTECTED VETERANS, AND REQUIRES AFFIRMATIVE ACTION BY COVERED PRIME CONTRACTORS AND SUBCONTRACTORS TO EMPLOY AND ADVANCE IN EMPLOYMENT QUALIFIED PROTECTED VETERANS.



Work Order

03/15/23
Page 1

Weather Engineers, Inc.
P.O. BOX 37068
Jacksonville, FL 32236
(904) 356-3963 Fax: (904) 356-4969
CAC041190

ABERDEEN CDD
475 W. TOWN PALCE STE 114
ST. AUGUSTINE FL 32092

ABERDEEN FITNESS CENTER
110 FLOWER OF SCOTLAND AVE
ST. JOHNS FL 32259

Call Slip Number
180086

Problem Reported:

PROB: MIS-MISC. REPAIR

billable/unit is on heat has burning smell & setting off alarm then unit shuts off/avail all day till 6/loc Amenity Center

Brand	Model	Serial #
AAON	H3-CRB-8-0-162C-3D2	202010-CJEC06278

Location: ATTIC

FITNESS CENTER.

Diagnostic: (1) Upon arrival smoke detector audio/strobe in ceiling was detach from ceiling and red low voltage to audio/strobe unit disconnected.

(2) In AAON FAN COIL control panel a jumper wire installed by another A/C company over the weekend between GND red wire and one black wire, and one white wire twisted together.

Action: I removed jumper wire connected in AAON control panel, reset and test smoke detector in attic at Fan Coil, mount audio/strobe smoke detector unit in ceiling, connect red wire, reset unit then check A/C operations, everything checked out ok.

Tech	Date	Hours
104	03/15/2023	1.2166 TT hours

Description	Amount
COUPON 100	0.00

Weather Engineers, Inc.
P.O. BOX 37068
Jacksonville, FL 32236
(904) 356-3963 Fax: (904) 356-4969
CAC041190

ABERDEEN CDD
475 W. TOWN PALCE STE 114
ST. AUGUSTINE FL 32092

ABERDEEN FITNESS CENTER
110 FLOWER OF SCOTLAND AVE
ST. JOHNS FL 32259

Call Slip Number

180086

All service labor and diagnostics will be warranted thirty (30) days from the date of initial service. Weather Engineers, Inc. warrants all service parts for a period of one (1) year from date of original installation provided time does not exceed the manufactures warranty period. Weather Engineers, Inc. shall provide new materials under warranty without charge for the part itself. This warranty does not include labor beyond the initial thirty (30) days or other cost incurred for diagnosis, repairing, removing, installing, shipping, servicing or handling of either the defective part or the replacement part or material. Warranty will be performed during normal business hours of 8:00 AM - 4:30 PM Monday thru Friday (only) excluding holidays. Thank You For Your Business!!

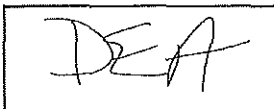

03/15/2023 04:25PM

Authorized Signature

Check Approval Form

General Fund

Date: March 31, 2023

District: Aberdeen CDD

Fund Code: 1

Beginning Check #: 4601

Ending Check #: 4604

Total Amount of Checks:	<u>\$ 57,995.91</u>	New Balance
Balance in Account***:	<u>\$ 155,738.95</u>	<u>\$ 97,743.04</u>

Recent Deposits: _____

Prepared by: Todd R. Polvere

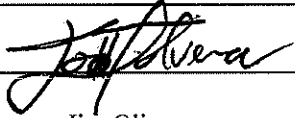
Signature: 

Approved by: Jim Oliver

Signature: _____

BANK A: ABERDEEN CDD

VEND NO.	Invoice Date	Vendor Inv. No.	---General Ledger#-----	St Cr	DUE DATE	GROSS AMOUNT	DISC AMOUNT	NET AMOUNT	CHECK PO#	CHECK NO.
00153	32323	51509067	001-320-57200-46000		32323	616.95	.00	616.95		
		FIRST AID/SAFETY	REPAIRS AND REPLACEMENTS							
		CINTAS FIRE 636525				616.95	.00	616.95	004601	
00259	31723	10872835	001-320-53800-45918		31723	3,096.10	.00	3,096.10		
		MAR GEN MNGR PROP OPER	FACILITY MANAGER							
00259	31723	10872835	001-320-53800-45917		31723	1,812.83	.00	1,812.83		
		MAR STAFF FRONT DESK	GENERAL FACILITY MAINTENANCE							
00259	31723	10872835	001-320-53800-45505		31723	1,704.90	.00	1,704.90		
		MAR STAFF GROUNDS MAINT	AMENT-POOL MAINTENANCE							
00259	31723	10872835	001-320-53800-46000		31723	2,609.56	.00	2,609.56		
		MAR SUPVSR BUILD MAINT	OPERATIONS MANAGEMENT							
00259	31723	10872835	001-320-53800-46000		31723	2,012.81	.00	2,012.81		
		MAR STAFF BUILD MAINT	OPERATIONS MANAGEMENT							
00259	32223	10873743	001-320-53800-45918		32223	698.00	.00	698.00		
		PROPERTY MANAGER	FACILITY MANAGER							
00259	32223	10873743	001-320-53800-45915		32223	698.00	.00	698.00		
		FRONT DESK	RESIDENT SERVICE COORDINATOR							
00259	32223	10873743	001-320-53800-45917		32223	698.00	.00	698.00		
		GROUNDS MAINTENANCE	GENERAL FACILITY MAINTENANCE							
00259	32223	10873743	001-320-53800-45917		32223	698.00	.00	698.00		
		MAINTENANCE SUPERVISOR	GENERAL FACILITY MAINTENANCE							
		FIRST SERVICE RESIDENTIAL				14,028.20	.00	14,028.20	004602	
00283	13023	19543	001-320-53800-46200		13023	21,547.38	.00	21,547.38		
		JAN LANDSCAPE MAINTENANCE	LANDSCAPE MAINTENANCE							
00283	32823	20047	001-320-53800-46200		32823	21,547.38	.00	21,547.38		
		MAR LANDSCAPE MAINT SRVC	LANDSCAPE MAINTENANCE							
		TREE AMIGOS				43,094.76	.00	43,094.76	004603	
00303	20723	1043	001-320-57200-49400		20723	256.00	.00	256.00		
		4/8 EVT FACE PAINTING	SPECIAL EVENTS							
		GINA PEAVEY DBA WACKY AND WHIMSICAL				256.00	.00	256.00	004604	
		ABERDEEN CDD				57,995.91	.00	57,995.91		
		ABERDEEN - GENERAL FUND				57,995.91	.00	57,995.91		

ABER ABERDEEN

TPOLVERE



CINTAS
 P.O. Box 631025
 CINCINNATI, OH 45263-1025

Service / Billing # (904)562-7000
 Fax # (904)562-7020
 Payment Inquiry # (972)996-7923

Invoice

Ship To ABERDEEN COMMUNITY
 DEVELOPMENT DISTRICT
 110 FLOWER OF SCOTLAND AVE
 ST JOHNS, FL 32259-6937

Invoice # 5150906725
 Invoice Date 03/23/2023
 Credit Terms NET 30 DAYS
 Customer # 21733123
 Cintas Route LOC #0292 ROUTE 0055
 Order # 7039108674
 Payer # 21733123

Bill To ABERDEEN COMMUNITY
 DEVELOPMENT DISTRICT
 110 FLOWER OF SCOTLAND AVE
 ST JOHNS, FL 32259-6937

1,320.572.460

Material #	Description	Quantity	Unit Price	Ext Price	Tax
Unit 000000000018653746	Unit Description:				
110	SERVICE ACKNOWLEDGEMENT	2 EA	\$0.00	\$0.00	
120	CABINET ORGANIZED	2 EA	\$0.00	\$0.00	
130	EXPIRATION DATES CHECKED	2 EA	\$0.00	\$0.00	
14129	CINTAS 4 SHELF FIRST AID CABINET	1 EA	\$224.00	\$224.00	
63039	COLD SPRAY 4 OZ	1 EA	\$20.00	\$20.00	
64039	BLOOD CLOTTER SPRAY 3 OZ	1 EA	\$30.00	\$30.00	
164010	COOL AND SOOTHE 6/BOX	1 BOX	\$25.00	\$25.00	
			Unit Subtotal:	\$299.00	
Unit 000000000018653747	Unit Description:				
14129	CINTAS 4 SHELF FIRST AID CABINET	1 EA	\$224.00	\$224.00	
63039	COLD SPRAY 4 OZ	1 EA	\$20.00	\$20.00	
64039	BLOOD CLOTTER SPRAY 3 OZ	1 EA	\$30.00	\$30.00	
164010	COOL AND SOOTHE 6/BOX	1 BOX	\$25.00	\$25.00	
			Unit Subtotal:	\$299.00	
Unit 000000000999900999	Unit Description:	Other			
400	SERVICE CHARGE	1 EA	\$18.95	\$18.95	
			Unit Subtotal:	\$18.95	
			Invoice Sub-total	\$616.95	
			Tax	\$0.00	
			Invoice Total	\$616.95	

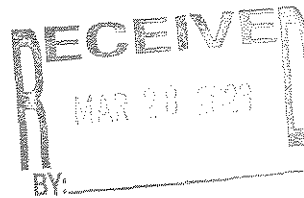

Remit To CINTAS
 P.O. Box 631025
 CINCINNATI, OH 45263-1025

Note

First Aid / Safety

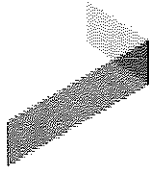

FirstService

RESIDENTIAL

Aberdeen Community Development District
110 Flower of Scotland Avenue
Saint Johns, FL 32259
Anh.Nguyen@fsresidential.com

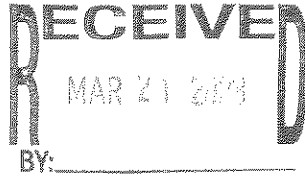

INVOICE

Invoice Number 10872835
Invoice Date 3/17/2023
Terms 15 ePay ACH BP
Period Start 2/25/2023
Period End 3/10/2023

Customer 100-0SNC
Account # PAY-0SNC
Total Amount Due: \$11,236.20

Position	Labor Rate	Employee	Hours	Pay Rate	Amount
General Manager, Property Oper <i>1,320.538.45918</i>	15.00%	Trivelpiece, Katherine	80.00 REGULAR	\$33.65	\$3,096.10
				Subtotal	\$3,096.10
Staff, Front Desk	25.00%	Arnold, Demetric E	4.00 OVERTIME	\$25.50	\$127.50
Staff, Front Desk <i>1,320.538.45917</i>	25.00%	Arnold, Demetric E	79.31 REGULAR	\$17.00	\$1,685.33
				Subtotal	\$1,812.83
Staff, Grounds Maint	25.00%	Abshire, Caleb L	8.83 OVERTIME	\$24.00	\$264.90
Staff, Grounds Maint <i>1,320.538.45505</i>	25.00%	Abshire, Caleb L	72.00 REGULAR	\$16.00	\$1,440.00
				Subtotal	\$1,704.90
Supervisor, Building Maint	25.00%	Parker, Jay	0.97 OVERTIME	\$39.00	\$47.29
Supervisor, Building Maint	25.00%	Parker, Jay	4.00 PTO	\$26.00	\$130.00
Supervisor, Building Maint	25.00%	Parker, Jay	73.30 REGULAR	\$26.00	\$2,382.27
Supervisor, Building Maint <i>1,320.538.460</i>	0.00%	Parker, Jay	CELL	\$50.00	\$50.00
				Subtotal	\$2,609.56
Staff, Building Maint	25.00%	Henry, Brandon E	5.00 OVERTIME	\$27.75	\$173.44
Staff, Building Maint <i>1,320.538.460</i>	25.00%	Henry, Brandon E	79.54 REGULAR	\$18.50	\$1,839.37
				Subtotal	\$2,012.81

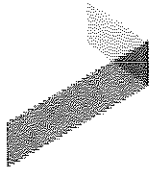

FirstService

RESIDENTIAL

Aberdeen Community Development District
110 Flower of Scotland Avenue
Saint Johns, FL 32259
Anh.Nguyen@fsresidential.com

INVOICE

Invoice Number 10872835
Invoice Date 3/17/2023
Terms 15 ePay ACH BP
Period Start 2/25/2023
Period End 3/10/2023

Customer 100-0SNC
Account # PAY-0SNC
Total Amount Due: \$11,236.20

Position	Labor Rate	Employee	Hours	Pay Rate	Amount
				Subtotal	\$11,236.20
				Tax	\$0.00
				Total	\$11,236.20
General Manager, Property Oper			\$3,096.10		
Staff, Building Maint			\$2,012.81		
Staff, Front Desk			\$1,812.83		
Staff, Grounds Maint			\$1,704.90		
Supervisor, Building Maint			\$2,609.56		

INVOICE



Aberdeen Community Development District
110 Flower of Scotland Avenue
Saint Johns, FL 32259
Anh.Nguyen@fsresidential.com

Invoice Number 10873743
Invoice Date 3/22/2023
Terms 15 ePay ACH BP
Period Begin 3/1/2023
Customer 100-0SNC
Account # MED-0SNC
Total Amount Due: \$2,792.00

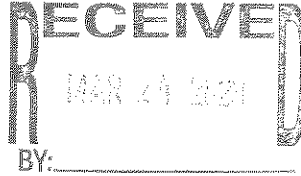

Medical Insurance

Date	Position	Employee	Amount
3/1/2023	Property Manager 1,320.538.45918	Trivelpiece, Katherine	\$698.00
		Subtotal	\$698.00
3/1/2023	Front Desk 1,320.538.45917	Arnold, Demetric E	\$698.00
		Subtotal	\$698.00
3/1/2023	Grounds Maintenance 1,320.538.45505	Abshire, Caleb L	\$698.00
		Subtotal	\$698.00
3/1/2023	Maintenance Supervisor 1,320.538.460	Parker, Jay	\$698.00
		Subtotal	\$698.00
			Subtotal \$2,792.00
			Tax \$0.00
			Total \$2,792.00



Tree Amigos

Outdoor Services

Invoice

Invoice#: 19543

Date: 01/30/2023

Billed To: Aberdeen CDD
475 W Town Place
#114
St. Augustine FL 32092

Project: Aberdeen CDD
571 Market St
St. Augustine FL 32095

Description	Quantity	Price	Ext Price
January monthly landscape maintenance	1.00	21,547.38	21,547.38

Notes:

Invoice Total: \$21,547.38

RECEIVED
MAR 24 2023
BY: _____

*Landscape Maint
Contract
001.320.53800.46200
#1
2/1/23*



Tree Amigos

Outdoor Services

Invoice

Invoice#: 20047

Date: 03/28/2023

Billed To: Aberdeen CDD
 475 W Town Place
 #114
 St. Augustine FL 32092

Project: Aberdeen CDD
 571 Market St
 St. Augustine FL 32095

Description	Quantity	Price	Ext Price
March Monthly Landscape Maintenance Service	1.00	21,547.38	21,547.38

Notes:

Invoice Total: \$21,547.38

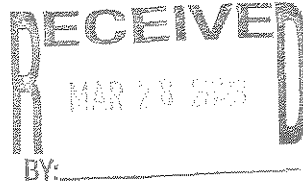

Landscape Contract
 320.53800.46200
 KA
 3.28.23

Wacky and Whimsical

Making your Party Wacky or Whimsical



Wacky and Whimsical LLC

20 Clan Crest Pl
Saint Johns, FL 32259 US
(845) 699-4066
gina@wackyandwhimsical.com
www.wackyandwhimsical.com

INVOICE

BILL TO
Kate Trivelpiece
Aberdeen CDD
110 Flower of Scotland Ave
Saint Johns, FL 32259

INVOICE 1043
DATE 02/07/2023
DUE DATE 04/08/2023

1,320.572.494

DATE	ACTIVITY	DESCRIPTION	QTY	RATE	AMOUNT
		\$50 discount community discount given			
04/08/2023	Face Painting Event	2 hour minimum event	1	200.00	200.00
04/08/2023	Face Painting - Extra 1/2 hour		2	50.00	100.00
04/08/2023	Credit Card Fee		1	6.00	6.00

Thank you for your business. I take ACH payments, Venmo payments, and Zelle payments.

ACH - Please click review and pay
Venmo - @wackyandwhimsical
Zelle - 845-699-4066

SUBTOTAL	306.00
DISCOUNT	-50.00
TOTAL	256.00

BALANCE DUE **\$256.00**

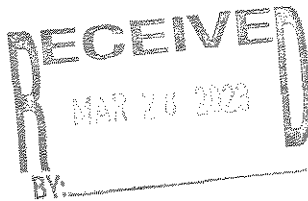

Special Events
* Please send check *
3.28.23

CHECK DATE	VEND#INVOICE..... DATE INVOICE	...EXPENSED TO... YRMO DPT ACCT# SUB SUBCLASS	VENDOR NAME	STATUS	AMOUNTCHECK..... AMOUNT #
3/09/23	00128	3/06/23 27663	202303 600-53800-60100	50% DEPOSIT UMBRELLA/VENT FIBERLITE UMBRELLAS INC.	*	798.37	798.37 000142
3/09/23	00183	3/02/23 PSF10194	202303 600-53800-60100	ROUND ACRYL TOP DIN TABLE FURNITURE LEISURE INC DBA POOL	*	4,237.78	4,237.78 000143
TOTAL FOR BANK B						5,036.15	
TOTAL FOR REGISTER						5,036.15	

Check Approval Form

Capital Reserve

Date: March 9, 2023

District: Aberdeen CDD - CR

Fund Code: 33

Beginning Check #: 142

Ending Check #: 143

Total Amount of Checks: \$ 5,036.15 New Balance
Balance in Account***: \$ 15,300.04 \$ 10,263.89

Recent Deposits: _____

Prepared by: Todd R. Polvere

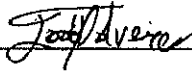
Signature: 

Approved by: Jim Oliver

Signature: _____

BANK B: CAPITAL RESERVE FUND

VEND NO.	Invoice Date	Vendor Inv. No.	---General Ledger#-----	St Cr	DUE DATE	GROSS AMOUNT	DISC AMOUNT	NET AMOUNT	CHECK PO#	CHECK NO.
00128	30623	27663	033-600-53800-60100		30623	798.37	.00	798.37		
			50% DEPOSIT UMBRELLA/VENT FIBERLITE UMBRELLAS INC.			798.37	.00	798.37	000142	
00183	30223	PSF10194	033-600-53800-60100		30223	4,237.78	.00	4,237.78		
			ROUND ACRYL TOP DIN TABLE FURNITURE LEISURE INC DBA POOL			4,237.78	.00	4,237.78	000143	
CAPITAL RESERVE FUND						5,036.15	.00	5,036.15		
ABERDEEN-CAPITAL RESERVE FUND						5,036.15	.00	5,036.15		

FIBERLITE UMBRELLAS, LLC

P.O. Box 600040, Jacksonville, FL 32260-0040
1.800.350.6615 PH 904.230.7552 FAX
email Ray@Fiberliteumbrellas.com

Invoice

Date	3/6/2023
Invoice #	27663

Payment Due Date	3/6/2023
------------------	----------

Bill To
ABERDEEN CDD 110 FLOWER OF SCOTLAND AVE ST JOHNS, FL 32259 USA

Ship To
ABERDEEN CDD 110 FLOWER OF SCOTLAND AVE ST JOHNS, FL 32259 USA

P.O. Number	Terms	Ship Date	Tracking Number	Ship Via	F.O.B.
1534	COD	3/6/2023			

Quantity	Item Code	Price Each	Description	Amount
4	FL7.5SM	325.00	7.5' Market cut umbrella with vent -8 ribs .305 ribs, 7.5' diameter- 1 PC CHAMPANGE POLE WITH FOREST GREEN FABRIC- OUTSIDE TIE	1,300.00
	shipping/handling	296.73	Shipping/ Handling	296.73

RECEIVED
MAR 06 2023
BY: _____

REMIT TO: FIBERLITE UMBRELLAS
P.O. BOX 600040
JACKSONVILLE, FL 32260-0040

PAST DUE FINANCE
CHARGE 1.5% PER
MONTH

Freight must be marked damage upon
delivery on the delivery ticket or the
customer will be responsible for all
damaged merchandise returned

Subtotal	\$1,596.73
Sales Tax (7.0%)	\$0.00
Payments/Credits	\$0.00
Balance Due	\$1,596.73

Fiberlite Umbrellas, LLC

P.O. Box 600040
 Jacksonville, FL 32260-0040
 800.350.6615 P 904.230.7552 F

PROPOSAL

Date	Estimate #
2/27/2023	1534

Name / Address
ABERDEEN CDD 110 FLOWER OF SCOTLAND AVE ST JOHNS, FL 32259 USA

Project

Item	Description	Qty	Rate	Total
FL7.5SM	7.5' Market cut umbrella with vent -8 ribs .305 ribs, 7.5' diameter- 1 PC CHAMPANGE POLE WITH FOREST GREEN FABRIC- OUTSIDE TIE	4	325.00	1,300.00
shipping/handling	Shipping/ Handling		296.73	296.73

RECEIVED
 MAR 02 2023
 BY: _____

Subtotal	\$1,596.73
Sales Tax (7.0%)	\$0.00
Total	\$1,596.73

* 50% Deposit *
 Due

*Capital Expense

033.600, 538.601



Phone: (877) 646-6320
 Fax : (386) 437-6652

A Furniture Leisure Web Store

Invoice

2729 E. Moody Blvd, STE #203
 Bunnell, FL 32110

Date	Invoice No.
3/2/2023	PFS10194

Bill To
Aberdeen CDD Kate Trivelpiece 110 Flower of Scotland Ave. St. Johns, FL 32259

Ship To
Aberdeen CDD Kate Trivelpiece 110 Flower of Scotland Ave. St. Johns, FL 32259 USA

S.O. No.	P.O. No.	Rep	Terms	Ship Date	Ship Via
PFS9894		KC	50%Deposit/Net	3/2/2023	

Item	Description	Qty	Cost	Total
WT4218AU	42" Round Acrylic Top Dining Table with umbrella hole., 1 1/2" x 3/4" Flat Tubing Frame. 30lbs. Frame Color: Bronze Age List: \$539.95	8	450.00	3,600.00

RECEIVED
 MAR 03 2023
 BY: _____

Thank you for your business. Please make all checks payable to:

Pool Furniture Supply
 2729 E. Moody Blvd, Suite 203
 Bunnell, FL 32110

Should the debt become past due, customer expressly agrees to pay a service fee of \$20.00 each month plus 2% per month of the balance due or the amount allowed by law. Customer also agrees to pay reasonable collection costs and/or attorneys fees incurred in connection with the collection of this account. The venue for any litigation regarding a credit account with Furniture Leisure, Inc. will be Flagler County, FL.

Subtotal
Sales Tax (0.0%)
Order Total
Payments/Credits
Balance Due

*Capital Expense
 KZ 3.1.23*

sales@poolfurnituresupply.com

www.poolfurnituresupply.com



Phone: (877) 646-6320
 Fax : (386) 437-6652

A Furniture Leisure Web Store

Invoice

2729 E. Moody Blvd, STE #203
 Bunnell, FL 32110

Date	Invoice No.
3/2/2023	PFS10194

Bill-To
Aberdeen CDD Kate Trivelpiece 110 Flower of Scotland Ave. St. Johns, FL 32259

Ship-To
Aberdeen CDD Kate Trivelpiece 110 Flower of Scotland Ave. St. Johns, FL 32259 USA

S.O. No.	P.O. No.	Rep	Terms	Ship Date	Ship Via
PFS9894		KC	50%Deposit/Net	3/2/2023	

Item	Description	Qty	Cost	Total
S&H	Shipping and Handling. Commercial Delivery Curbside - Delivery does not include offloading freight. Lift Gate and 24 hr Call Ahead are requested for all applicable orders but are not guaranteed. - The delivery address must have ample room for a 53' semi truck to enter and turn around or exit the property without incident or obstacle. Notify your Sales Rep if a smaller truck is required. - Certain products will ship unassembled. Delivery does not include assembly, installation, placement of furniture, or removal of packing materials.	1	637.78	637.78

RECEIVED
 MAR 03 2023
 BY: _____

Thank you for your business. Please make all checks payable to:

Pool Furniture Supply
 2729 E. Moody Blvd, Suite 203
 Bunnell, FL 32110

Should the debt become past due, customer expressly agrees to pay a service fee of \$20.00 each month plus 2% per month of the balance due or the amount allowed by law. Customer also agrees to pay reasonable collection costs and/or attorneys fees incurred in connection with the collection of this account. The venue for any litigation regarding a credit account with Furniture Leisure, Inc. will be Flagler County, FL.

Subtotal	\$4,237.78
Sales Tax (0.0%)	\$0.00
Order Total	\$4,237.78
Payments/Credits	\$0.00
Balance Due	\$4,237.78

sales@poolfurnituresupply.com

www.poolfurnituresupply.com